



FAIRCHILD

CATALOG 207-K



VARIABLE SPEED TRANSMISSION

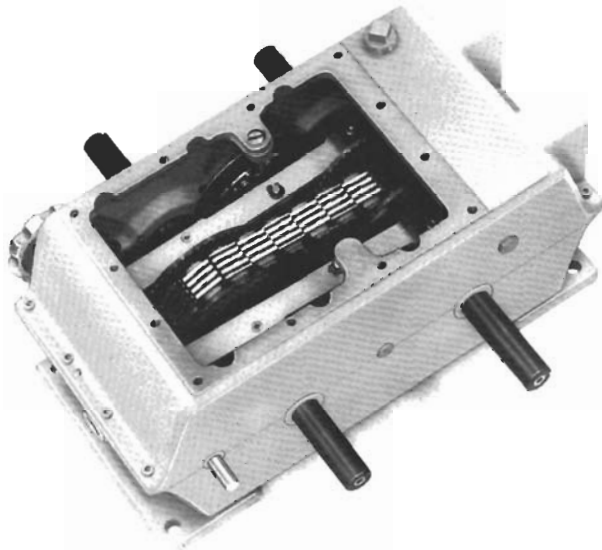

APPLICATIONS

For Industrial Processes that require exact variable speed control and positive power transmission.

The VARI-CHAIN variable speed transmission is used to control metering, tensioning and knife rolls in material converting machinery, and for controlling feed and tension in wire feed machinery. It may be used in:

Printing Presses
Textile Machinery
Paper Converting
Synthetic Fiber Machinery
Alternator Drives

FEATURES

- # Infinitely adjustable to any speed setting within rated speed range
- # Self adjusting variable pitch all metal chain
- # Available in speed ranges of 2:1,3:1,4:1,5:1 and 6:1. 0 and 1/2 models have ranges of up to 5:1 and 4:1 respectively
- # Adjustable ratio limits on all except 0 and 1/2 models
- # Accurate speed indicator

- # Horizontal or vertical mounting
- # Self contained splash lubrication
- # All metal construction
- # Compact design
- # Oil level sight gages
- # Multiple shaft arrangement
- # Gearing, integral motor, vernier control, and remote control options are available
- # Split Housing Construction

BENEFITS

- # Eliminates step adjusting of speed

- # Assures positive power transmission
- # Covers speed requirements of most industrial processes

- # Allows field reset to reduce speed range
- # Shows control screw turns. Relates input to output speed ratio
- # Allows space conservation
- # Minimum maintenance required
- # Assures long life and higher torque transmission
- # Allows easy mounting on machinery
- # Allows instant determination of oil level
- # Covers most applications of input and output
- # Accommodates special speed requirements, allows finer speed adjustment
- # Facilitates maintenance

SPECIFICATIONS

CAPACITIES AND RATINGS

Specon VARI-CHAIN Transmissions are available in a large variety of speed ranges and input speeds. The Rating Table lists power capacity and speed ranges for the Style I various size units which are available.

All models are designed for use with single stage input and/or output gearing to accommodate special speed requirements. These are designated Style II or Style III transmissions.

Two stage, three stage, and four stage output gearing designated Style IV or Style IV/IV transmissions are also available.

STYLE I

Style I VARI-CHAIN transmissions contain the basic variable pitch chain and an input and output shaft. A summary of characteristics appears below:

Specon VARI-CHAIN transmissions are also available in power capacities up to 45 HP; speed ranges of 1.4:1, 2:1, and 2.5:1 are available in these power sizes. These units, designated with the suffix VCD after the size number incorporate the basic VARI-CHAIN transmission and an appropriately connected differential to shunt power around the adjustable sheave chain. The higher power Specon VARI-CHAIN transmission is rated at constant torque throughout the speed range. Selection for constant torque applications are therefore obvious. Size selection for constant power applications should be based on unit power capacities at minimum speed.

See Catalog 202 for VCD functional description and Rating table.

SPEED RANGE	#3	#4	#5	FOR SPEED RANGE
	1.4:1	1.4:1	1.4:1	
	2:1	2:1	2:1	
INPUT R.P.M.	1540	1235	1235	1.4:1
	1350	1080	1080	2:1
	1260	1010	1010	2.5:1
OUTPUT R.P.M.	1280-1800	1030-1440	1030-1440	1.4:1
	400-1860	720-1440	720-1440	2:1
	720-1800	580-1440	580-1440	2.5:1
TORQUE* MAXIMUM SPEED LB. IN.	790	1310	1970	1.4:1
	745	1220	1970	2:1
	625	1070	1840	2.5:1
TORQUE* MINIMUM SPEED LB. IN.	790	1310	1970	1.4:1
	745	1220	1970	2:1
	625	1070	1840	2.5:1

SPEED RANGE	#0	#1/2	#1	#2	#3	#4	#5	FOR SPEED RANGE
	2:1	2:1	2:1	2:1	2:1	2:1	2:1	
	3:1	3:1	3:1	3:1	3:1	3:1	3:1	
	4:1	4:1	4:1	4:1	4:1	4:1	4:1	
	5:1		5:1	5:1	5:1	5:1	5:1	
		6:1	6:1	6:1	6:1	6:1		
INPUT R.P.M.	720	720	900	900	900	720	720	2:1
	720	720	900	900	900	720	720	3:1
	720	720	900	900	900	720	720	4:1
	720		720	720	720	600	600	5:1
			720	720	720	600	600	6:1
TORQUE* MAXIMUM SPEED LB. IN.	55	90	140	215	340	575	955	2:1
	45	80	115	190	285	470	780	3:1
	40	65	100	165	250	405	675	4:1
	35		75	150	195	330	565	5:1
			65	115	180	300	515	6:1
TORQUE* MINIMUM SPEED LB. IN.	85	140	200	315	495	825	1400	2:1
	85	140	200	330	495	855	1510	3:1
	80	140	200	330	495	810	1510	4:1
	80		165	330	440	825	1550	5:1
			165	330	440	770	1550	6:1

STYLE II

Style II VARI-CHAIN transmissions incorporate a single stage input or output gear set. The standard ratios listed below are available in this configuration. Stock ratios are shown in bold face type. These ratios can be used as the single stage gear set in Style II,II/II,III/II, and IV/II transmissions.

	RATIO LIMITS						
	#0	#1/2	#1	#2	#3	#4	#5
Input Reduction	1.000 to	1.000 to	1.000 to	1.000 to	1.000 to	1.000 to	1.000 to
Output Step Up	3.500	4.058	6.143	6.118	5.125	5.889	5.889
Output Reduction	1.000 to	1.000 to	1.000 to	1.000 to	1.000 to	1.000 to	1.000 to
Input Step Up	3.500	4.058	6.143	6.118	5.125	5.889	5.889
	ACTUAL RATIOS						
	#0	#1/2	#1	#2	#3	#4	#5
	1.000	1.000 3.526	1.000 2.846	1.000 2.846	1.000 2.920	1.000 2.263	1.000 2.263
	1.057	1.047 3.777	1.041 3.000	1.041 3.000	1.042 3.083	1.033 2.351	1.033 2.351
	1.118	1.097 4.059	1.083 3.167	1.083 3.167	1.085 3.261	1.067 2.444	1.067 2.444
	1.182	1.150	1.128 3.348	1.128 3.348	1.130 3.455	1.102 2.543	1.102 2.543
	1.250	1.205	1.174 3.545	1.174 3.545	1.178 3.667	1.138 2.647	1.138 2.647
	1.323	1.263	1.222 3.762	1.222 3.654	1.227 3.900	1.175 2.758	1.175 2.758
	1.400	1.324	1.273 4.000	1.273 3.840	1.279 4.158	1.214 2.875	1.214 2.875
	1.483	1.389	1.326 4.263	1.326 4.042	1.333 4.444	1.255 3.000	1.255 3.000
	1.571	1.457	1.381 4.556	1.381 4.261	1.390 4.765	1.296 3.133	1.296 3.133
	1.667	1.529	1.439 4.882	1.439 4.500	1.450 5.125	1.340 3.276	1.340 3.276
	1.769	1.606	1.500 5.250	1.500 4.762	1.513	1.385 3.429	1.385 3.429
	1.880	1.687	1.564 5.667	1.564 5.050	1.579	1.431 3.593	1.431 3.593
	2.000	1.775	1.632 6.143	1.632 5.368	1.649	1.480 3.769	1.480 3.769
	2.130	1.866	1.703	1.703 5.722	1.722	1.531 3.960	1.531 3.960
	2.273	1.965	1.778	1.778 6.118	1.800	1.583 4.167	1.583 4.167
	2.429	2.071	1.857	1.857	1.882	1.638 4.391	1.638 4.391
	2.600	2.185	1.941	1.941	1.970	1.696 4.636	1.696 4.636
	2.789	2.307	2.030	2.030	2.063	1.756 4.905	1.756 4.905
	3.000	2.440	2.125	2.125	2.161	1.818 5.200	1.818 5.200
	3.235	2.583	2.226	2.226	2.267	1.884 5.526	1.884 5.526
	3.500	2.739	2.333	2.333	2.379	1.952 5.889	1.952 5.889
		2.909	2.448	2.448	2.500	2.024	2.024
		3.095	2.571	2.571	2.630	2.100	2.100
		3.300	2.704	2.704	2.769	2.179	2.179

STYLE III - INTEGRAL MOTOR

All Specon transmissions can be supplied with integrally mounted drive motors to provide a complete adjustable speed drive. These are designated as Style III transmissions. All sizes of VARI-CHAIN transmissions are available in Style III configuration with the following a-c induction motor sizes. Motors are generally available in open-drip-proof, TEFC and explosion proof frames. Standard motors are rated 230/460V, 60 hertz, 3 phase. Consult the factory for *other motor specifications and service requirements.

Motor Sizes Available						
#0	#1/2	#1	#2	#3	#4	#5
1/2 HP, 3/4 HP	1/2 HP, 3/4 HP	1 HP, 1 1/2 HP	1 1/2 HP, 2 HP	2 HP, 3 HP	3 HP, 5 HP	7 1/2 HP, 10 HP
1 HP	1 HP, 1 1/2 HP	2 HP, 3 HP	3 HP, 5 HP	5 HP, 7 1/2 HP	7 1/2 HP, 10 HP	15 HP, 20 HP

*AC Synchronous type for electrical line shaft applications using variable frequency.

STYLE IV – MULTIPLE REDUCTION

Style IV VARI-CHAIN transmissions can be supplied with 2,3, or 4 stage gearing on either the input, output or both sides of the transmission. Maximum gear ratios for this style are listed. Consult the factory for ratio requirements compatible with the application.

Maximum Ratios							
	# 0	# ½	# 1	# 2	# 3	# 4	# 5
2-Stage	13	15	12	12	20	23	27
3-Stage	49	61	36	36	80	108	108
4-Stage	184	238	108	108	240	334	334

Note: HP capacities of 3 or 4-stage Style IV VARI-CHAIN transmissions may be reduced. Consult factory for approval of power rating.

SPEED RANGE

– 2:1 to 6:1 – Most Specon Variable Speed Transmission sizes are available with overall speed ranges of 2:1, 3:1, 4:1, 5:1 and 6:1. Size 0 and size ½ units have speed ranges up to 5:1 and 4:1 respectively.

SPEED ADJUSTMENT

All Specon VARI-CHAIN transmissions have an indicator located in the control hand wheel. This indicator shows control screw turns and therefore relates input/output speed ratio. The indicator shows control screw turns and parts of turns, assuring a high degree of repeatability.

HORIZONTAL OR VERTICAL MOUNTING – (Page 5)

All models can be mounted either horizontal or vertical. The foot mounting design of sizes 2 thru 5 VARI-CHAIN Variable Speed Transmissions may be specified to permit field conversion of horizontal mounted units to vertical mounted units and vice versa.

Note: Size 1 VARI-CHAIN may also be specified to permit field conversion on a special order basis.



FIGURE 2
CONTROL HAND WHEEL INDICATOR

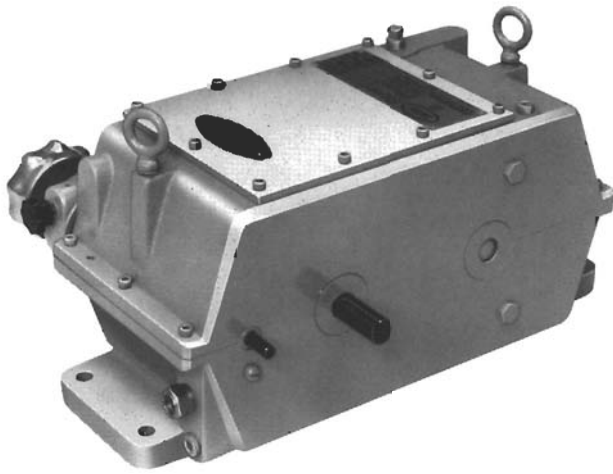

STYLE I HORIZONTAL



STYLE I VERTICAL

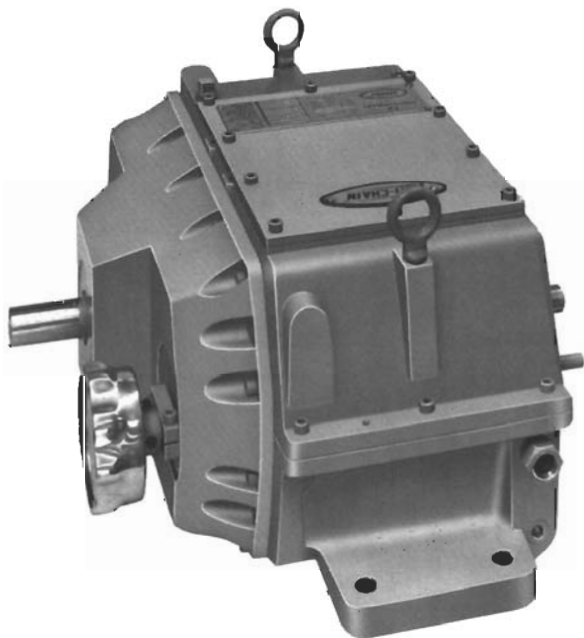

STYLE II HORIZONTAL

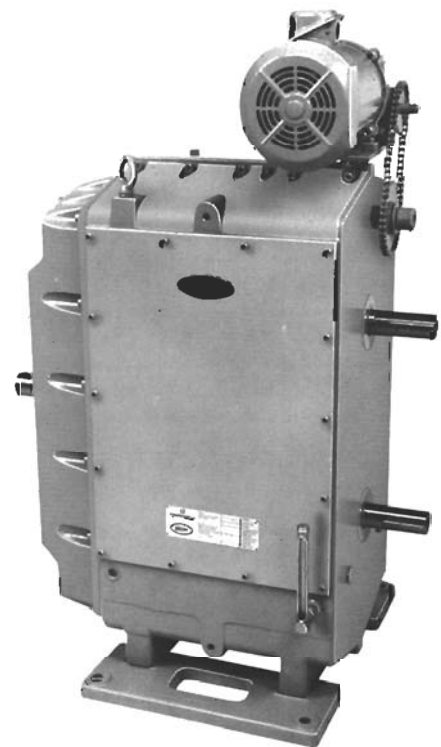

STYLE II VERTICAL

OUTLINE DIMENSIONS

Style I - Horizontal

Style I - Vertical

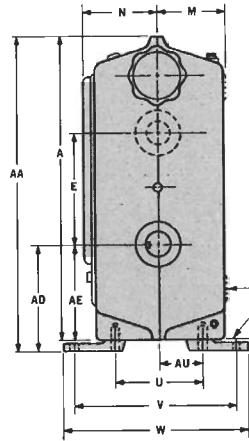
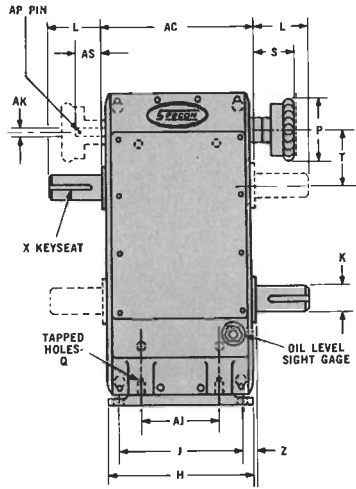

THESE SURFACES CAN BE MACHINED AND CAN BE USED FOR MOUNTING IF REQUIRED. REFER TO MOUNTING AND OUTLINE DIMENSIONS FOR HORIZONTAL UNITS FOR BOLT SPECS. AND LOCATION.

THESE SURFACES CAN BE MACHINED AND CAN BE USED FOR MOUNTING IF REQUIRED. REFER TO MOUNTING AND OUTLINE DIMENSIONS FOR VERTICAL UNITS FOR BOLT HOLE SPECS. AND LOCATION.

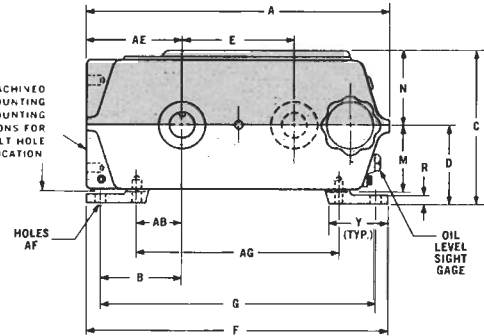
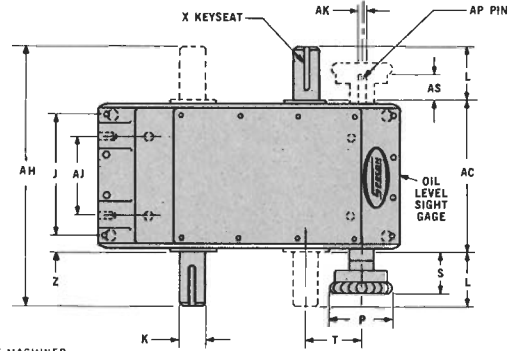

NOTE: 1. Mounting pads can be interchangeable for both horizontal and vertical mounting, except on sizes 0, 1/2, and 1-72, 1-79, and 1-84 where pads are integrally cast with the housing.

2. Shaft tolerances plus 0.0000; minus 0.0005

FIGURE 3

FIGURE 4

SIZE	A	B	C	D	E	F	G	H	J	K	L	M	N	P	Q	R	S	T	U
	INCHES																		
0	12 ¹³ / ₁₆	3 ⁵ / ₈	6 ⁵ / ₈	3 ¹ / ₂	4 ³ / ₄	13	12	4 ¹ / ₄	3 ¹ / ₄	¹ / ₆	1 ³ / ₈		3 ¹ / ₈	3		⁵ / ₈	2 ¹ / ₄	2 ⁷ / ₁₆	
1/2	16	5 ³ / ₈	8 ¹ / ₈	4	5 ¹ / ₂	17 ³ / ₄	16 ¹ / ₄	5	3 ¹ / ₂	³ / ₄	1 ¹ / ₈		4 ¹ / ₈	3 ¹ / ₂		⁷ / ₈	2 ¹ / ₄	3 ³ / ₈	
1-72 1-79 1-84	17 ¹ / ₂ **	5 ³ / ₄ **	8 ⁵ / ₈ **	4 ¹ / ₂	6 ¹ / ₂	19 ¹ / ₂ **	18 **	8 ³ / ₄	4 ¹ / ₂ **	1 ⁵ / ₆	2 ³ / ₈		4 ¹ / ₈ **	3 ¹ / ₂	**	1 **	2 ¹ / ₁₆	3 ³ / ₄	**
2	22 ³ / ₄	6 ¹ / ₄	11 ¹ / ₁₆	6 ³ / ₁₆	8 ³ / ₈	22 ³ / ₄	21 ¹ / ₈	12 ¹ / ₄	10 ⁵ / ₈	1 ¹ / ₈	2 ³ / ₄	5 ⁵ / ₁₆	5 ⁵ / ₈	3 ¹ / ₂	¹ / ₂	1	2 ¹ / ₂	4 ¹³ / ₃₂	6 ⁵ / ₈
3	26 ³ / ₈	7 ⁵ / ₈	13 ¹ / ₄	7	10 ¹ / ₄	26 ³ / ₄	25 ¹ / ₂	14 ¹ / ₈	12 ¹ / ₄	1 ⁵ / ₁₆	3 ¹ / ₂	6	6 ¹ / ₄	6	¹ / ₂	1	3 ³ / ₈	5 ³ / ₈	8
4	32 ¹ / ₄	8 ¹ / ₂	15 ³ / ₄	8 ¹ / ₄	13	32	30	16	14	1 ¹ / ₁₆	4	7 ¹ / ₄	7 ¹ / ₂	6	⁵ / ₈	1	3 ¹³ / ₁₆	6 ¹ / ₂	7 ¹ / ₂
5	39 ¹ / ₂	10 ⁵ / ₈	19 ⁵ / ₈	10 ¹ / ₁₆	16	39 ¹ / ₂	37 ¹ / ₄	19 ⁵ / ₈	17 ¹ / ₂	1 ³ / ₄	4 ¹ / ₂	8 ¹⁵ / ₁₆	9 ³ / ₁₆	6	⁷ / ₈	1 ¹ / ₂	3 ³ / ₄	8 ¹ / ₁₆	10 ⁷ / ₈

SIZE	V	W	X-Keyseat	Y	Z	AA	AB	AC	AD	AE	AF	AG	AH	AJ	AK	AP	AS	AU
	INCHES																	
0	7	8	¹ / ₈ x ¹ / ₁₆ x 1 ¹ / ₄	4	1 ⁵ / ₈	12 ⁷ / ₈		6 ¹ / ₂	4		¹ / ₃₂		9 ¹ / ₄		^{.3148} / _{.3144}	¹ / ₄ -20	1	
1/2	8 ¹ / ₄	9 ³ / ₄	³ / ₁₆ x ³ / ₃₂ x 1 ⁵ / ₈	4 ¹ / ₈	1 ¹⁵ / ₁₆	16 ¹ / ₄		7 ³ / ₈	5 ¹ / ₂		¹ / ₃₂		11 ¹ / ₈		^{.3750} / _{.3745}	¹ / ₄ -20	1 ¹ / ₈	
1-72 1-79 1-84	9 ¹ / ₂	11	¹ / ₄ x ¹ / ₈ x 2 ³ / ₈ **	4 ¹ / ₂ **	2 ³ / ₁₆ **	18 **	— **	8 ²⁹ / ₃₂ **	6 **	— **	¹ / ₃₂ **	— **	13 ⁵ / ₈ **	— **	^{.3935} / _{.3931} **	¹ / ₄ -20 **	1 ¹ / ₁₆ **	— **
2	12	13 ⁵ / ₈	¹ / ₄ x ¹ / ₈ x 2 ⁵ / ₈	4 ³ / ₈	1	23 ³ / ₄	3 ³ / ₁₆	12 ⁵ / ₈	8 ¹ / ₁₆	7 ¹ / ₁₆	¹ / ₃₂	15 ¹ / ₄	18 ¹ / ₈	7 ³ / ₄	^{.5506} / _{.5495}	¹ / ₄ -20	1 ³ / ₈	3 ⁵ / ₁₆
3	14 ⁷ / ₈	16 ¹ / ₈	³ / ₁₆ x ⁵ / ₃₂ x 3 ¹ / ₂	5	1 ⁵ / ₁₆	27 ³ / ₈	4 ³ / ₁₆	14 ¹ / ₈	9	8	¹ / ₃₂	18 ⁵ / ₈	21 ³ / ₁₆	9	^{.5506} / _{.5495}	¹ / ₄ -20	1 ¹ / ₂	4
4	14 ¹ / ₂	16 ¹ / ₂	³ / ₈ x ³ / ₁₆ x 3 ³ / ₄	6	1 ¹ / ₈	33 ¹ / ₄	5	16 ¹ / ₄	10 ⁵ / ₈	9 ⁵ / ₈	¹ / ₁₆	23	24 ³ / ₁₆	10 ¹ / ₂	^{.6294} / _{.6283}	¹ / ₄ -20	1 ⁵ / ₈	3 ³ / ₄
5	20 ¹ / ₈	22 ³ / ₈	³ / ₈ x ³ / ₁₆ x 4 ¹ / ₄	7 ³ / ₈	1 ¹ / ₁₆	41	6	19 ⁷ / ₈	13 ¹ / ₄	11 ³ / ₄	² / ₃₂	28	28 ⁷ / ₈	13 ¹ / ₂	^{.6294} / _{.6283}	¹ / ₄ -20	1 ¹³ / ₁₆	5 ⁷ / ₁₆

**Dimensions which are different from previous size 1 VARI-CHAIN transmission.

Style II – Vertical

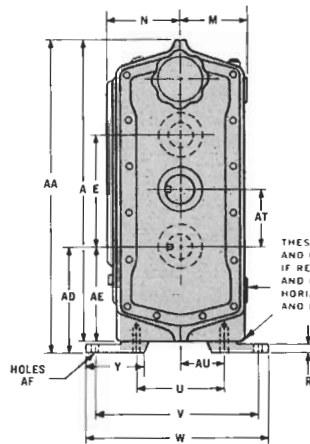
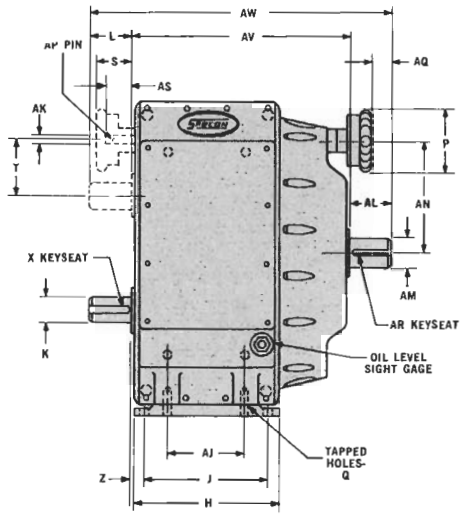

THESE SURFACES CAN BE MACHINED AND CAN BE USED FOR MOUNTING IF REQUIRED REFER TO MOUNTING AND OUTLINE DIMENSIONS FOR HORIZONTAL UNITS FOR BOLT SPECS AND LOCATION

THESE SURFACES CAN BE MACHINED AND CAN BE USED FOR MOUNTING IF REQUIRED REFER TO MOUNTING AND OUTLINE DIMENSIONS FOR VERTICAL UNITS FOR BOLT HOLE SPECS AND LOCATION

Style II – Horizontal

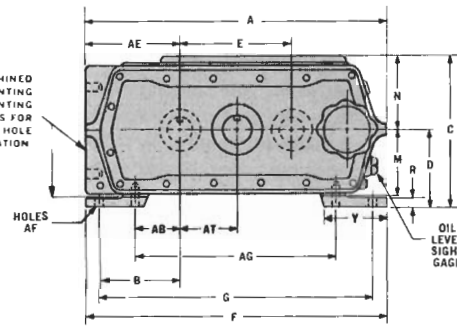
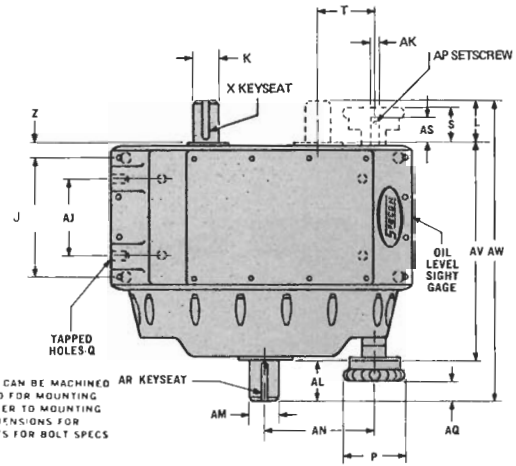

NOTE: 1. Mounting pads can be interchangeable for both horizontal and vertical mounting, except on sizes 0, 1/2, and 1-72, 1-79, and 1-84 where pads are integrally cast with the housing.

2. Shaft tolerances plus 0.0000; minus 0.0005

FIGURE 5

FIGURE 6

SIZE	A	B	C	D	E	F	G	H	J	K	L	M	N	P	Q	R	S	T	U	V	W	X-Keseat
	INCHES																					
0	12 ¹³ / ₁₆	3 ⁵ / ₈	6 ⁵ / ₈	3 ¹ / ₂	4 ³ / ₄	13	12	4 ¹ / ₄	3 ³ / ₄	1 ⁵ / ₁₆	1 ³ / ₈		3 ³ / ₈	3		5 ⁵ / ₈	2 ¹ / ₄	2 ¹ / ₁₆		7	8	1 ¹ / ₈ x 1 ¹ / ₈ x 1 ¹ / ₄
1/2	16	5 ³ / ₈	8 ¹ / ₈	4	5 ¹ / ₂	17 ³ / ₄	16 ¹ / ₄	5	3 ¹ / ₂	3 ⁴ / ₈	1 ⁷ / ₈		4 ¹ / ₈	3 ¹ / ₂		7 ⁵ / ₈	2 ¹ / ₄	3 ¹ / ₈		8 ¹ / ₄	9 ³ / ₄	3 ¹ / ₈ x 3 ¹ / ₃₂ x 1 ⁵ / ₈
1-72 1-79 1-84	17 ¹ / ₂ **	5 ³ / ₄ **	8 ⁵ / ₈ **	4 ¹ / ₂	6 ¹ / ₂	19 ¹ / ₂ **	18 **	8 ³ / ₄	4 ¹ / ₂ **	1 ⁵ / ₁₆	2 ³ / ₈		4 ¹ / ₈ **	3 ¹ / ₂	— **	1 **	2 ¹ / ₁₆	3 ¹ / ₄	— **	9 ¹ / ₂	11 **	1 ¹ / ₄ x 1 ¹ / ₈ x 2 ³ / ₈ **
2	22 ³ / ₄	6 ¹ / ₄	11 ¹ / ₁₆	6 ³ / ₁₆	8 ⁵ / ₈	22 ³ / ₄	21 ¹ / ₈	12 ¹ / ₄	10 ⁵ / ₈	1 ¹ / ₈	2 ³ / ₄	5 ³ / ₁₆	5 ³ / ₈	3 ¹ / ₂	1 ¹ / ₂	1	2 ⁵ / ₁₆	4 ¹³ / ₃₂	6 ⁵ / ₈	12	13 ⁵ / ₈	1 ¹ / ₄ x 1 ¹ / ₈ x 2 ⁵ / ₈
3	26 ³ / ₈	7 ⁵ / ₈	13 ³ / ₄	7	10 ¹ / ₄	26 ³ / ₄	25 ¹ / ₂	14 ¹ / ₈	12 ¹ / ₄	1 ¹ / ₁₆	3 ¹ / ₂	6	6 ¹ / ₄	6	1 ¹ / ₂	1	3 ⁵ / ₈	5 ³ / ₈	8	14 ⁷ / ₈	16 ¹ / ₈	5 ¹ / ₁₆ x 5 ¹ / ₃₂ x 3 ¹ / ₂
4	32 ¹ / ₄	8 ¹ / ₂	15 ³ / ₄	8 ¹ / ₄	13	32	30	16	14	1 ¹ / ₁₆	4	7 ¹ / ₄	7 ¹ / ₂	6	5 ⁵ / ₈	1	3 ¹ / ₁₆	6 ¹ / ₂	7 ¹ / ₂	14 ¹ / ₂	16 ¹ / ₂	3 ³ / ₈ x 3 ¹ / ₁₆ x 3 ³ / ₄
5	39 ¹ / ₂	10 ⁵ / ₈	19 ⁵ / ₈	10 ⁵ / ₁₆	16	39 ¹ / ₂	37 ¹ / ₄	19 ⁵ / ₈	17 ¹ / ₂	1 ³ / ₄	4 ¹ / ₂	8 ¹ / ₁₆	9 ³ / ₁₆	6	7 ⁵ / ₈	1 ¹ / ₂	3 ³ / ₄	8 ¹ / ₁₆	10 ⁷ / ₈	20 ⁵ / ₈	22 ³ / ₈	3 ³ / ₈ x 3 ¹ / ₁₆ x 4 ¹ / ₄

SIZE	Y	Z	AA	AB	AD	AE	AF	AG	AJ	AK	AL	AM	AN	AP	AQ	AR-Keseat	AS	AT	AU	AV	AW
	INCHES																				
0	4	1 ⁵ / ₈	12 ⁷ / ₈		4		1 ¹³ / ₃₂			.3148 .3144	1 ⁵ / ₈	3 ³ / ₄	4 ¹³ / ₁₆	1/4-20	1 ¹ / ₁₆	3 ¹ / ₁₆ x 3 ¹ / ₃₂ x 1 ³ / ₈	1	2 ³ / ₈		9 ¹ / ₁₆	12 ⁷ / ₁₆
1/2	4 ¹ / ₈	1 ¹⁵ / ₁₆	16 ¹ / ₄		5 ¹ / ₂		1 ¹⁷ / ₃₂			.3750 .3745	2	1	5 ⁷ / ₈	1/4-20	1 ¹ / ₃₂	1 ¹ / ₄ x 1 ¹ / ₈ x 1 ⁷ / ₈	1 ¹ / ₈	2 ¹ / ₄		11 ¹ / ₃₂	15 ¹⁵ / ₃₂
1-72 1-79 1-84	4 ¹ / ₂ **	2 ³ / ₁₆ **	18 **	— **	6 **	— **	1 ¹⁷ / ₃₂ **	— **	— **	.3935 .3931	2 ¹ / ₁₆	1 ¹ / ₈	6 ¹ / ₂	1/4-20 **	1 ¹ / ₁₆	1 ¹ / ₄ x 1 ¹ / ₈ x 2 ³ / ₈	1 ¹ / ₁₆	3 ¹ / ₄	— **	12 ¹³ / ₁₆ **	17 ⁵ / ₈
2	4 ³ / ₈	1	23 ³ / ₄	3 ³ / ₁₆	8 ¹ / ₁₆	7 ¹ / ₁₆	1 ¹⁷ / ₃₂	15 ³ / ₄	7 ³ / ₄	.5506 .5495	2 ³ / ₄	1 ¹ / ₄	8 ²³ / ₃₂	1/4-20	1 ¹ / ₈	1 ¹ / ₄ x 1 ¹ / ₈ x 2 ⁵ / ₈	1 ¹ / ₈	4 ³ / ₁₆	3 ⁵ / ₁₆	17 ¹ / ₈	22 ⁵ / ₈
3	5	1 ⁵ / ₁₆	27 ³ / ₈	4 ³ / ₁₆	9	8	1 ¹⁷ / ₃₂	18 ⁵ / ₈	9	.5506 .5495	3 ³ / ₁₆	1 ¹ / ₂	10 ¹⁵ / ₃₂	1/4-20	3 ¹ / ₄	3 ³ / ₈ x 3 ¹ / ₁₆ x 3 ³ / ₄	1 ¹ / ₂	5 ⁵ / ₈	4	18 ¹ / ₁₆	25 ⁵ / ₈
4	6	1 ¹ / ₈	33 ³ / ₄	5	10 ⁵ / ₈	9 ⁵ / ₈	1 ¹¹ / ₁₆	23	10 ¹ / ₂	.6294 .6283	4	1 ³ / ₄	13	1/4-20	1 ¹ / ₁₆	3 ³ / ₈ x 3 ¹ / ₁₆ x 3 ⁵ / ₈	1 ⁵ / ₈	6 ¹ / ₂	3 ³ / ₄	21 ³ / ₁₆	29 ⁹ / ₁₆
5	7 ³ / ₈	1 ¹ / ₁₆	41	6	13 ¹ / ₄	11 ³ / ₄	2 ² / ₃₂	28	13 ¹ / ₂	.6294 .6283	4 ¹ / ₂	2 ¹ / ₄	16 ¹ / ₁₆	1/4-20	2 ³ / ₁₆	1 ¹ / ₂ x 1 ¹ / ₄ x 4 ³ / ₈	1 ¹ / ₁₆	8	5 ⁵ / ₁₆	26	35

**Dimensions which are different from previous size 1 VARI-CHAIN transmission.

Style II/II – Vertical

Style II/II – Horizontal

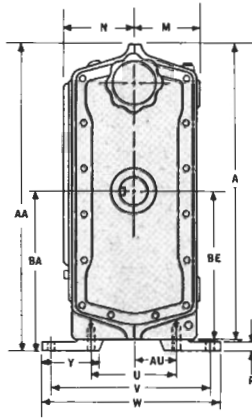
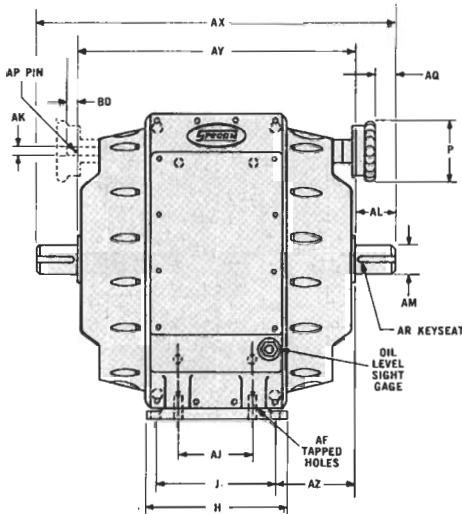

THESE SURFACES CAN BE MACHINED AND CAN BE USED FOR MOUNTING IF REQUIRED REFER TO MOUNTING AND OUTLINE DIMENSIONS FOR HORIZONTAL UNITS FOR BOLT SPECS. AND LOCATION

THESE SURFACES CAN BE MACHINED AND CAN BE USED FOR MOUNTING IF REQUIRED REFER TO MOUNTING AND OUTLINE DIMENSIONS FOR VERTICAL UNITS FOR BOLT HOLE SPECS. AND LOCATION

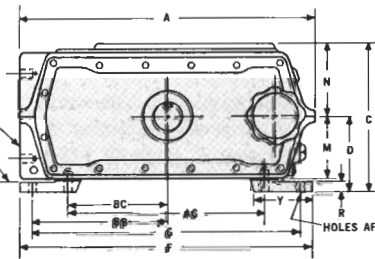
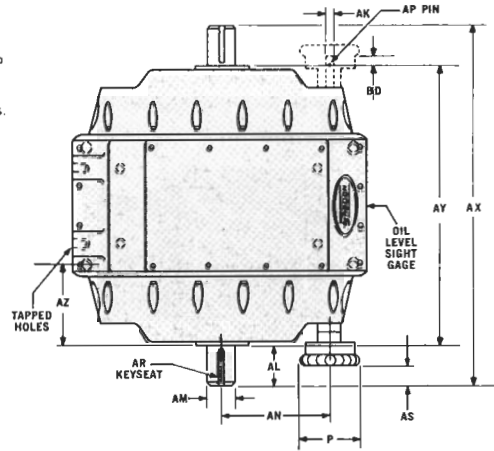

NOTE: 1. Mounting pads can be interchangeable for both horizontal and vertical mounting, except on sizes 0, 1/2, and 1-72, 1-79, and 1-84 where pads are integrally cast with the housing.

2. Shaft tolerances plus 0.0000; minus 0.0005

FIGURE 7

FIGURE 8

SIZE	A	C	D	F	G	H	J	M	N	P	Q	R	U	V	W	Y	AA	AF	AG
	INCHES																		
0	12 ¹³ / ₁₆	6 ⁵ / ₈	3 ¹ / ₂	13	12	4 ¹ / ₄	3 ¹ / ₄		3 ³ / ₈	3		5 ⁵ / ₈		7	8	4	12 ⁷ / ₈	1 ¹³ / ₃₂	
1/2	16	8 ¹ / ₈	4	17 ³ / ₄	16 ¹ / ₄	5	3 ¹ / ₂		4 ¹ / ₈	3 ¹ / ₂		7 ⁵ / ₈		8 ¹ / ₄	9 ³ / ₄	4 ¹ / ₈	16 ¹ / ₄	1 ¹⁷ / ₃₂	
1-72 1-79 1-84	17 ¹ / ₂ **	8 ⁵ / ₈ **	4 ¹ / ₂	19 ¹ / ₂ **	18 **	8 ³ / ₄	4 ¹ / ₂ **		4 ¹ / ₈ **	3 ¹ / ₂	— **	1 **	— **	9 ¹ / ₂	11 **	4 ¹ / ₂ **	18 **	1 ¹⁷ / ₃₂ **	— **
2	22 ³ / ₄	11 ¹ / ₈	6 ¹ / ₁₆	22 ³ / ₄	21 ¹ / ₈	12 ¹ / ₄	10 ⁵ / ₈	5 ⁵ / ₁₆	5 ³ / ₈	3 ¹ / ₂	1/2	1	6 ⁵ / ₈	12	13 ⁵ / ₈	4 ³ / ₈	23 ³ / ₄	1 ¹⁷ / ₃₂	15 ³ / ₄
3	26 ³ / ₈	13 ¹ / ₄	7	26 ³ / ₈	25 ¹ / ₂	14 ¹ / ₈	12 ¹ / ₄	6	6 ¹ / ₄	6	1/2	1	8	14 ⁷ / ₈	16 ¹ / ₈	5	27 ³ / ₈	1 ¹⁷ / ₃₂	18 ⁵ / ₈
4	32 ¹ / ₄	15 ³ / ₄	8 ¹ / ₄	32	30	16	14	7 ¹ / ₄	7 ¹ / ₂	6	5/8	1	7 ¹ / ₂	14 ¹ / ₂	16 ¹ / ₂	6	33 ¹ / ₄	1 ¹ / ₁₆	23
5	39 ¹ / ₂	19 ⁵ / ₈	10 ¹ / ₁₆	39 ¹ / ₂	37 ¹ / ₄	19 ⁵ / ₈	17 ¹ / ₂	8 ¹ / ₁₆	9 ³ / ₁₆	6	7/8	1 ¹ / ₂	10 ⁷ / ₈	20 ¹ / ₈	22 ³ / ₈	7 ³ / ₈	41	2 ²⁹ / ₃₂	28

SIZE	AJ	AK	AL	AM	AN	AP	AQ	AR-Keyseat	AU	AY	AX	AZ	BA	BB	BC	BD	BE	
	INCHES																	
0		.3148 .3144	1 ⁵ / ₈	3/4	4 ¹ / ₁₆	1/4-20	1/8	3/16 x 3/32 x 1 ¹ / ₈			12 ³ / ₈	15 ⁵ / ₈	4 ¹ / ₁₆	6 ³ / ₈	6		-7/16	
1/2		.3750 .3745	2	1	5 ⁵ / ₈	1/4-20	1 ¹ / ₃₂	1/4 x 1/8 x 1 ¹ / ₈			14 ¹ / ₁₆	18 ¹ / ₁₆	5 ²³ / ₃₂	8 ¹ / ₄	8 ¹ / ₈		-7/16	
1-72 1-79 1-84	— **	.3925 .3981	2 ¹ / ₁₆	1 ¹ / ₈	6 ¹ / ₂	1/4-20 **	1 ⁵ / ₁₆	1/4 x 1/8 x 2 ³ / ₈	— **		16 ¹ / ₄	21 ⁵ / ₈	6 ¹ / ₈ **	9 ¹ / ₄ **	9 **	— **	1 ¹¹ / ₃₂ **	— **
2	7 ¹ / ₄	.5506 .5495	2 ³ / ₄	1 ¹ / ₄	8 ²³ / ₃₂	1/4-20	1 ¹ / ₈	1/4 x 1/8 x 2 ⁵ / ₈	3 ⁵ / ₁₆		21 ⁵ / ₈	27 ¹ / ₈	5 ¹ / ₂	12 ³ / ₈	10 ¹ / ₁₆	7 ³ / ₈	5 ¹ / ₁₆	11 ³ / ₈
3	9	.5506 .5495	3 ¹ / ₁₆	1 ¹ / ₂	10 ¹ / ₂	1/4-20	3/4	5/16 x 5/32 x 3 ¹ / ₄	4		23 ³ / ₈	30	5 ¹ / ₁₆	14 ¹ / ₈	12 ³ / ₄	9 ¹ / ₁₆	5 ³ / ₈	13 ³ / ₈
4	10 ¹ / ₂	.6294 .6283	4	1 ³ / ₄	13	1/4-20	1 ¹ / ₁₆	3/8 x 3/16 x 3 ⁵ / ₈	3 ³ / ₄		26 ¹ / ₁₆	34 ¹ / ₁₆	6 ¹ / ₁₆	17 ³ / ₈	15	11 ¹ / ₂	1/4	16 ¹ / ₈
5	13 ¹ / ₂	.6294 .6283	4 ¹ / ₂	2 ¹ / ₄	16 ¹ / ₁₆	1/4-20	2 ¹ / ₁₆	1/2 x 1/4 x 4 ³ / ₈	5 ⁵ / ₁₆		32 ¹ / ₈	41 ¹ / ₈	7 ⁵ / ₁₆	21 ¹ / ₄	18 ⁵ / ₈	14	5/16	19 ³ / ₄

**Dimensions which are different from previous size 1 VARI-CHAIN transmission.

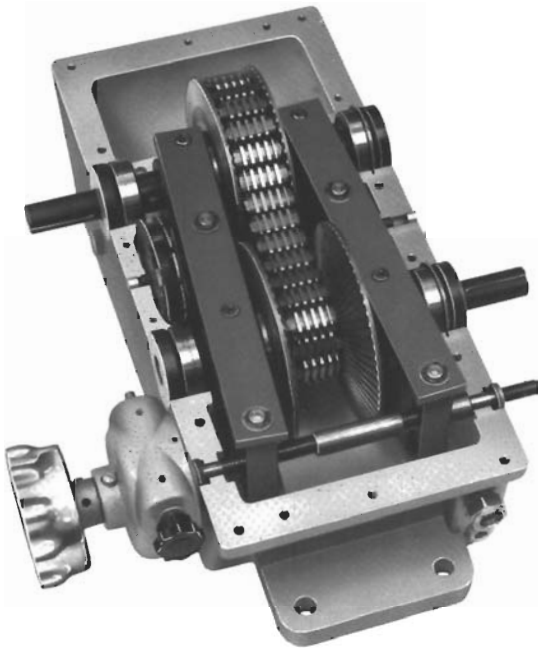

FIGURE 9
SPLIT HOUSING CONSTRUCTION
72,79 Configuration

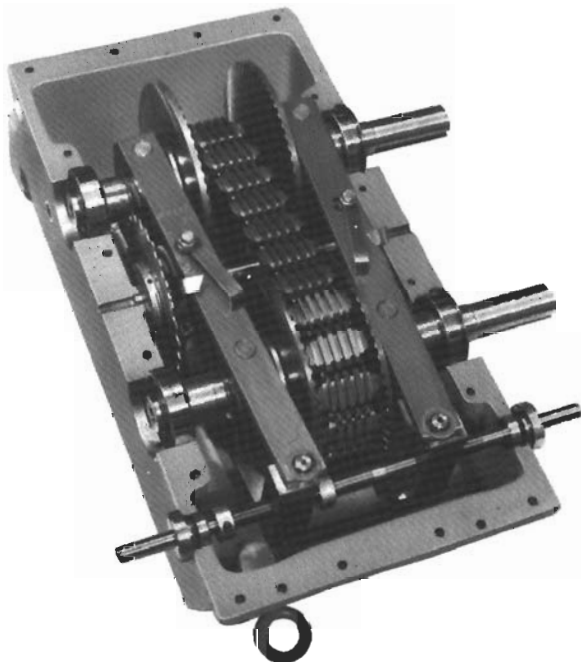

FIGURE 10
SPLIT HOUSING CONSTRUCTION
-84 Configuration



FIGURE 11
Oil Level Sight Gages

SPLIT HOUSING CONSTRUCTION – (Fig. 9 & 10)

All Specon Variable Speed Transmission housings are of split design to facilitate maintenance. An inspection cover is still provided for normal routine maintenance checks and chain installation when necessary.

The 72, 79 and 84 configurations of the VARI-CHAIN are physically and functionally the same. Internally, the chain tensioning and wear mechanisms, and the locking provisions, are different.

The Customer will need to furnish information from the identification plate in order to secure the proper repair parts when necessary. See SERVICE INFORMATION on Page 15.

SELF-CONTAINED SPLASH LUBRICATION

VARI-CHAIN Variable Speed Transmissions are designed for self-splash lubricating of all wear points. The chain and bearings will be adequately splash lubricated unless the input shaft is run continuously at very low speeds. Consult the factory on slow speed applications.

OIL LEVEL SIGHT GAGES – (Fig. 11)

Oil level sight gages are standard on all Specon Variable Speed Transmissions. The oil level within the transmission can instantly be determined through the oil level sight gage.

PRINCIPLES OF OPERATION

The Specon VARI-CHAIN Variable Speed Transmission consists of an all metal chain containing packages of slats, which engage themselves in grooved wheel-faces and thus effectively provide a variable pitch all metal chain.

The chain positions itself and establishes a pitch radius in the wheelfaces depending upon the opening between the wheelfaces. If the wheelfaces are moved close together, the chain rides out near the top of the wheelfaces and establishes itself with a relatively large pitch diameter. If the wheel faces are moved apart, the chain rides down near the center of the wheel-faces, establishing a relatively small pitch diameter. The resultant speed relationship between the variable speed shaft of the unit and the constant speed shaft of the unit is a function of the ratio of the pitch diameters of the chain at the variable speed grooved wheels and the constant speed grooved wheels.

The principle is the same regardless of whether a rubber belt with flat wheelfaces is used, or whether an all metal variable pitch chain, such as that in the VARI-CHAIN transmission, is used in conjunction with grooved wheelfaces. Figures 14 and 15 show this speed relationship at the variable speed shaft and the constant speed shaft as the effective pitch radius or pitch diameter is at each extreme point. A typical unit may be defined as having a four to one speed range. At the maximum speed condition, the effective pitch diameter of the chain at the variable speed sheaves will be one half of the pitch diameter at the constant speed sheaves.

At the other extreme, the effective pitch diameter at the constant speed shaft is one half of the effective pitch diameter at the variable speed shaft, resulting in a two to one reduction from the constant speed shaft to the variable speed shaft. Thus the resultant extreme speeds at the variable speed shaft are one half of the constant speed shaft speed and two times the constant speed shaft speed. This example is based on the use of a 4:1 ratio chain. If another chain ratio is used, the maximum speed at the variable speed shaft will be the square root of the ratio times constant speed shaft or input shaft speed, and the minimum speed would be input speed divided by the square root of the speed range of the selected unit.

The control levers and the control screw (figure 16) permit the wheelfaces to be adjusted in and out to an infinite number of positions and thus an infinite number of pitch diameter ratios can be established. This

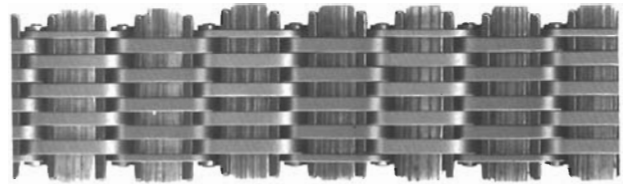

FIGURE 12
ALL METAL CHAIN

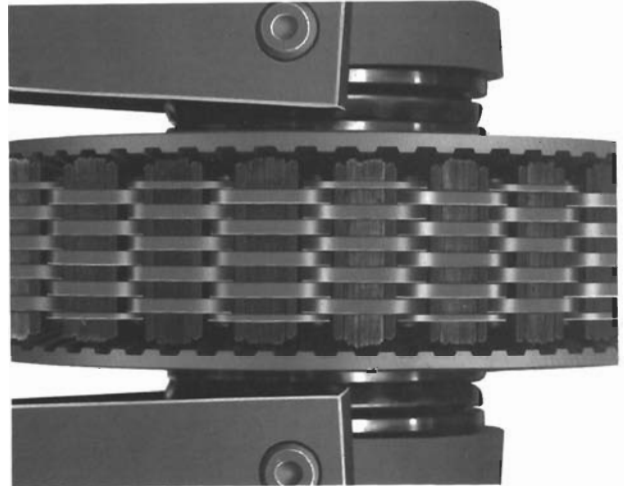

FIGURE 13
CHAIN IN WHEELFACE

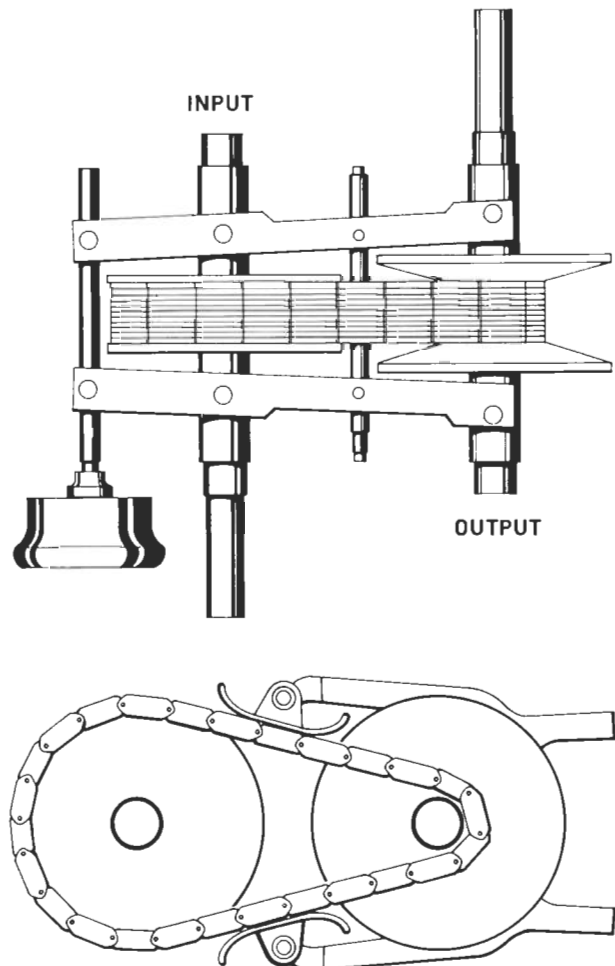
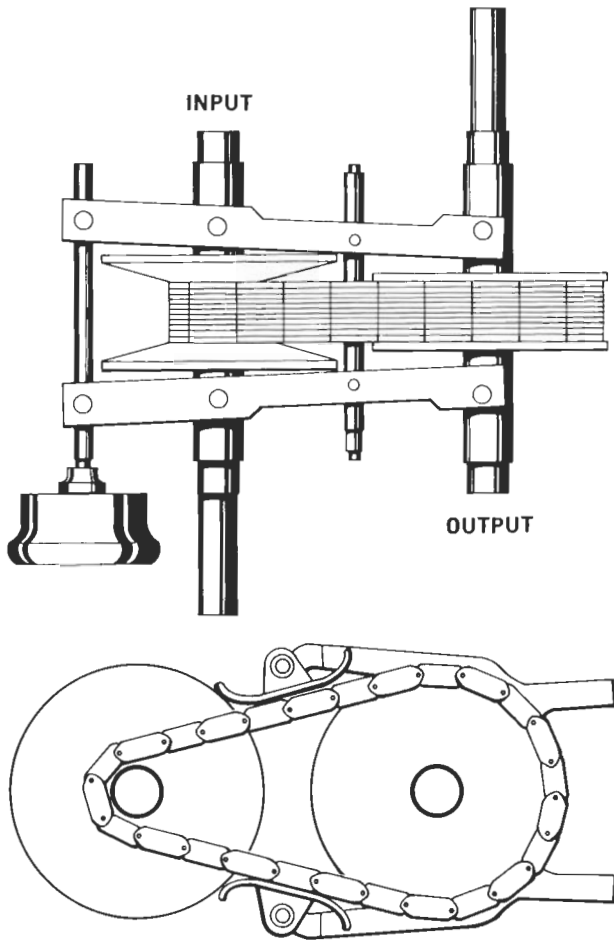

FIGURE 14
MAXIMUM SPEED SETTING

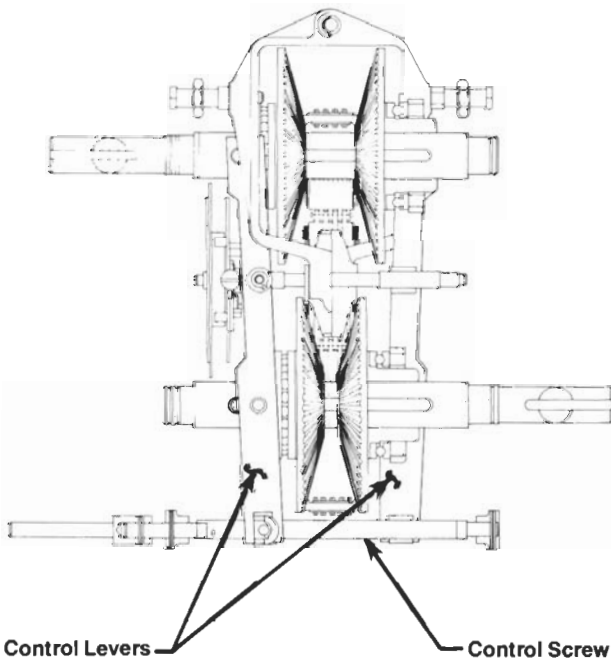

**FIGURE 15
MINIMUM SPEED SETTING**

means that the transmission is infinitely adjustable from maximum rated speed down to minimum rated speed. The unit can be set to operate at any speed setting between the maximum and minimum speed ratings.

The heart of the Specon VARI-CHAIN transmission is the variable pitch chain. The chain is made up of a number of packets of slats. Each packet contains approximately 30 slats, which are free to move laterally with respect to the center line of the chain and independently of each other. The slats themselves can assume any configuration which is forced upon them. The chain engages in the wheelfaces, which are radially grooved. These grooves are narrower near the center of the wheelface and widen out to the outer edge of the wheelface. The wheelfaces are set on drive shafts in such a way that a groove in one wheelface is directly opposite the raised portion of the matching wheelface. Therefore, as the chain comes in contact with the wheelface, the grooves and teeth of opposing wheelfaces force the slats of the chain into position and thus establish a firm mechanical connection between the driving and driven wheelfaces.

All Specon VARI-CHAIN Variable speed transmissions are equipped with a completely automatic chain tensioner. This feature maintains proper tension on the chain throughout its entire life and does not require shutting down of the unit to check or adjust chain tension. The only time the transmission needs to be shut down is to change the oil or replace the chain.



**FIGURE 16
VARI-CHAIN CONTROL LEVERS**

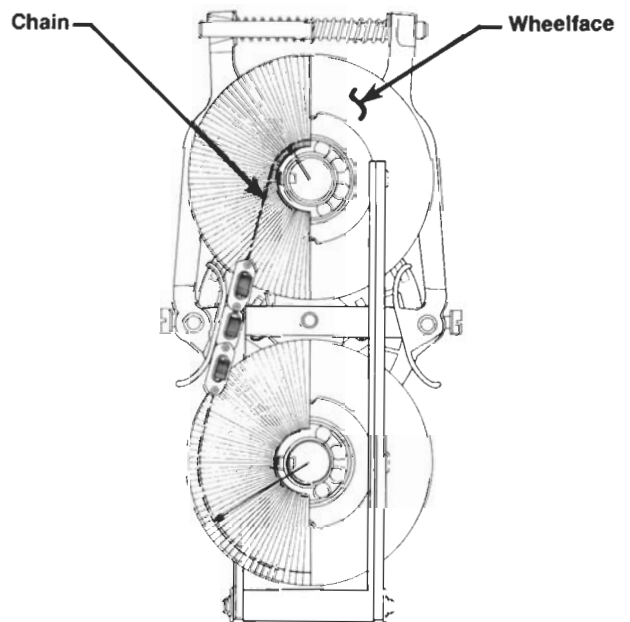

Chain Tensioner

Two types of automatic chain tensioning devices are used in the VARI-CHAIN transmission. Figures 17 and 18 illustrate the chain tensioning devices found in VARI-CHAIN Models 1 through 5 (-66,-72,-79) and Models 0 and 1/2 (-71,-72,-79) respectively. Although there are differences in the construction of the two tensioning devices, the principle of operation is the same.

A spiral spring(A) is used to exert torque on the pivot block screw(E). When the chain is new, the spiral spring is fully torqued. As wear occurs on the chain slats, the pivot block screw, which supports the two pivot blocks(G), turns under the effect of the spiral spring and compensates for wear on the chain. The chain remains under correct tension until it is completely worn out.

The progressive wear of the chain can easily be checked during oil change operations. An indicator wheel(B) is used on VARI-CHAIN Model sizes 1 through 5 to give an indication of the wear that has occurred to the chain. Once the 4/4 (or replace chain) mark is reached, the tensioning device is blocked by stops located on the tension flange(D) and the indicator wheel. No more tightening action takes place. The amount of wear on the chain in the 0, 1/2 VARI-CHAIN model sizes must be determined by examining the chain. The chain in any VARI-CHAIN unit should not be allowed to wear beyond the recommended minimum chain width. (see IOM for this unit). Usually maximum wear will occur when the pivot block screw has made slightly less than one revolution.

Chain and Chain Wear

Under normal applications of the Specon VARI-CHAIN transmission, the chain will be the primary wearing part. Since the wheel faces are at a greater hardness than the chain slats, the tips of the slats will wear first, reducing chain width. Chain wear may also occur on link connecting pins and bushings. The overall wear on the chain will produce a chain slackening which is automatically compensated for by the built in automatic chain tensioner. During the life of the chain, no adjustments for chain slackening or chain tension are necessary.

A chain wear indicator plate is included in the automatic chain tensioner assembly for Model sizes 1 through 5. This plate turns as the chain wears and the marking 0, 1/4, 1/2, 3/4 and 4/4 on the plate indicates the relative wear. For the Models(-84), automatic chain tensioning for normal operating speeds is equivalent to the SPIRAL SPRING type of tensioning in the Models(-66,-71,-72, and -79). Better control of chain tension is achieved at extremely slow speeds by the tension assemblies integrally mounted in the pivot blocks.

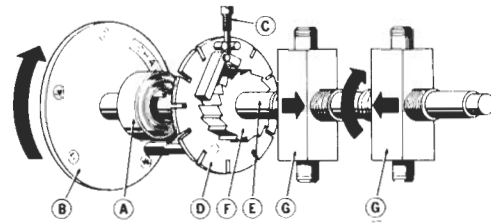

FIGURE 17
MODELS 1 THROUGH 5

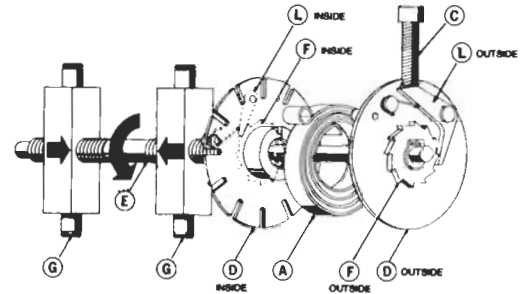

FIGURE 18
MODELS 0 AND 1/2

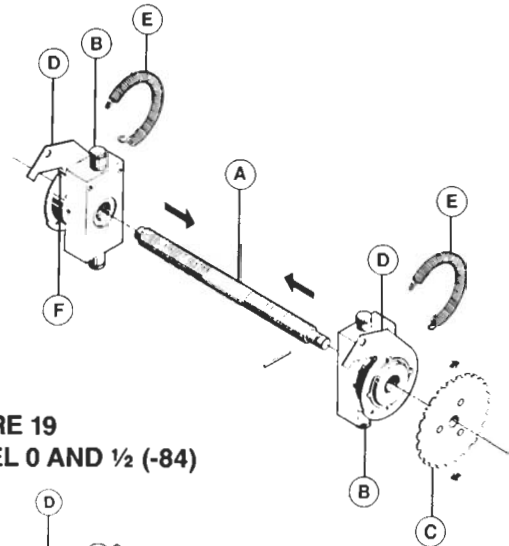

FIGURE 19
MODEL 0 AND 1/2 (-84)

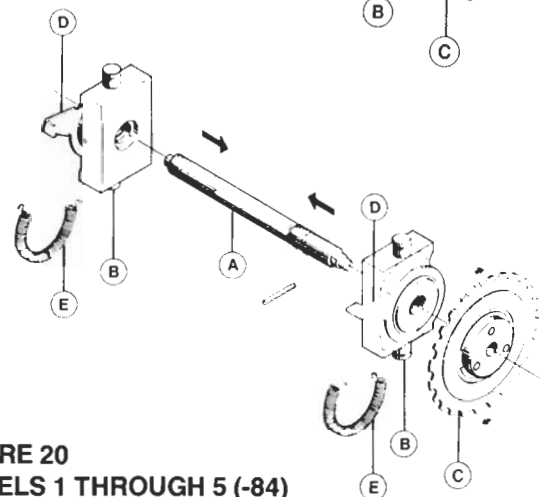

FIGURE 20
MODELS 1 THROUGH 5 (-84)

The Automatic Chain Tensioning Assembly consists of:

- Adjusting Screw(A) with right and left hand threads
- Two pivot blocks(B) mounted on the adjusting screw which contain individual tensioning mechanisms.
- Notched Tension Adjusting Flange(C)
- Chain Wear Indicating Arms(D)
- Springs(E) which move the indicating arms(D) as the chain wears and the tension mechanism in the pivot block(B) relaxes due to chain wear.

The progressive wear of the chain can be checked concurrent with oil change operations. The Chain Wear Indicating Arms(D) on the 0-84 and 1/2-84 VARI-CHAIN transmissions serve the same purpose as the numbered disc on the "SPIRAL SPRING" type automatic chain tensioner. They will move down toward red pointers located on top of the control lever(not shown) and come to rest on pins(F) supporting springs(E) when the chain is completely worn. For -84 models other than size 0 and 1/2, the Chain Wear Indicating Arms are formed into pointers bent at right angles to the arms. When the chain is completely worn, the pointers come to rest on the Control Levers. In either case, the Indi-

cator Arms should not be allowed to travel to the fullest extent of their range before the chain is replaced.

STYLES OF SPECON VARI-CHAIN VARIABLE SPEED TRANSMISSIONS AND DRIVES

Specon variable speed transmissions are available in a variety of configurations utilizing input or output gearing. The speed, torque, and power capacities given in the RATING TABLE are for the basic Style I transmissions. In order to utilize these ratings at other than rated input speeds at the input or output side of the transmission, it is necessary to incorporate gearing to translate required input or output shaft speeds to the rated speed at the input or output shaft of the basic transmission. The arrangements shown below indicate the variety of styles that are available with input and/or output gearing.

Transmissions are also available with integrally mounted drive motors and these units are appropriately designated for Styles III, III/II and IV/III.

STYLE I — Horizontal and Vertical

The Style I configuration incorporates the basic transmission.

Arrows Show Fixed Relative Rotations

Actual Rotation May Be In Either Direction

Either Shaft May Be Specified As Input

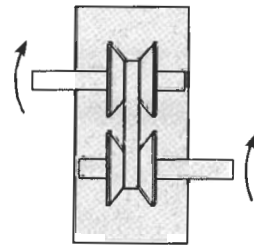

STYLE II — Horizontal and Vertical

The Style II configuration incorporates the basic transmission and one integrally housed gear set. The gearing can be step-up or reduction at the input or output side of the transmission.

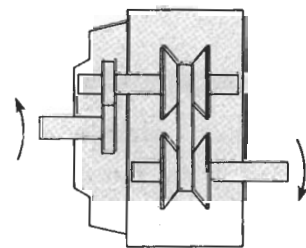

STYLE II/II — Horizontal and Vertical

The Style II/II configuration incorporates the basic transmission and two integrally housed gear sets. Either gear set can be step-up or reduction.

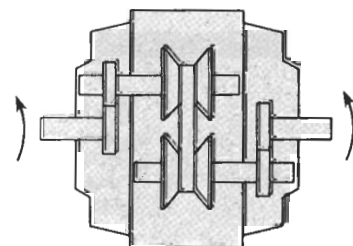

STYLE III — Horizontal and Vertical

The Style III configuration incorporates the basic transmission with an integrally mounted drive motor through an input gear set.

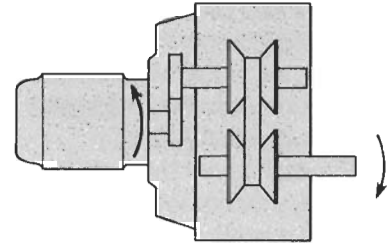

STYLE III/II — Horizontal and Vertical

The Style III/II configuration incorporates the basic transmission, an integrally mounted drive motor and an output gear set. The output gear set can be step-up or reduction.

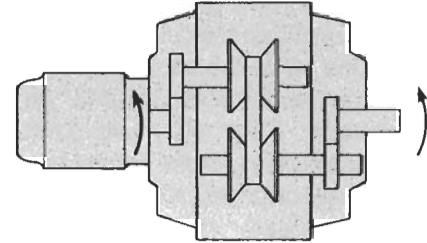

STYLE IV — Horizontal and Vertical

The Style IV configuration incorporates the basic transmission and one integrally housed two-stage gear set. The gearing can be step-up or reduction and can be used at the input or output side of the transmission.

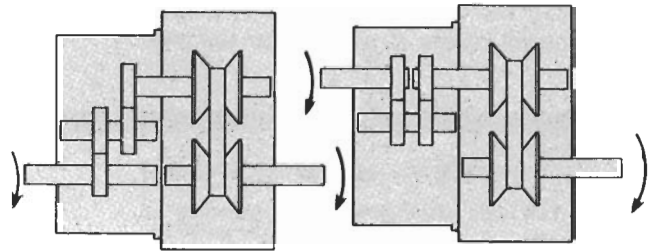

Style IV configurations are also available with 3 or 4 stage gearing.

STYLE IV/II — Horizontal and Vertical

The Style IV/II configuration incorporates the basic transmission, one integrally housed 2, 3, or 4-stage gear set and one integrally housed single-stage gear set. Either gear set can be step-up or reduction and either gear set could be used as the input or the output.

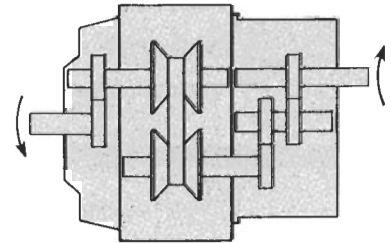

STYLE IV/III — Horizontal and Vertical

The Style IV/III configuration incorporates the basic transmission, an integral drive motor and an integrally housed 2, 3, or 4-stage output gear set. The output gear set can either be step-up or reduction.

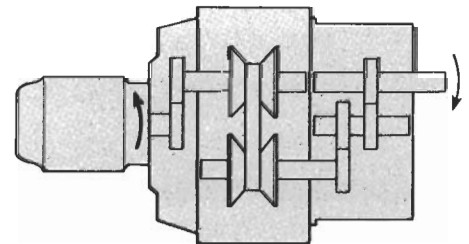

STYLE IV/IV — Horizontal and Vertical

The Style IV/IV configuration incorporates the basic transmission and two integrally housed two-stage gear sets. Either gear set can be step-up or reduction.

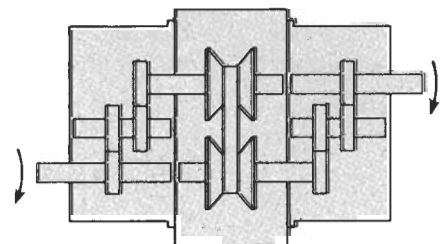

SELECTION

The selection of a proper Specon VARI-CHAIN transmission for the application can be accomplished by following the steps as outlined below. Basically it is only necessary to match the speed, torque, and power requirements of a transmission with the speed, torque, and power requirements of the application utilizing an appropriate service factor.

Determine overall ratio or speed range required of driven machine or output of transmission.

Determine the power demands of the driven machine at maximum speed and at minimum speed.

$$HP = \frac{T \cdot S}{63,000 S} \quad T = \text{Torque - Lb. In.}$$

$$S = \text{Speed - RPM}$$

Considering the application and usage of the transmission, apply the appropriate service factor as obtained from the following table:

OPERATING HOURS PER DAY	STOPS AND STARTS	SERVICE FACTOR
8-10	Infrequent	1
8-10	Frequent	1.33
10-24	Infrequent	1.33
10-24	Frequent	1.67

Determine input speed and HP.

Select proper model number from rating table. For constant HP applications, use minimum speed ratings. For constant torque applications, use maximum speed ratings.

Determine mounting arrangement to fit the installation. Styles and assemblies are shown on page 18 through 21. Refer to page 3 for ratios available when input or output gearing is required.

Overhung load – Overhung load capacity need not be considered when the input and output shafts of the transmission are directly coupled to the driving and driven shafts of the machine. This is the ideal type of installation.

If connecting media such as gearing, chain or belting is utilized, some consideration must be given to the overhung load.

On Style I transmissions if the gear, pulley or sprocket is large enough to fit on a standard shaft (diameter & length), the overhung load will not be in excess of the transmission capacity.

On Style II and Style II/II, Style III/II, Style IV/II transmissions, the overhung load capacity of the transmission will not be exceeded if the gear, pulley or sprocket pitch diameter is 3 to 3½ times the standard shaft diameter. The shaft referred to in this instance is the input or output shaft connected to the single stage gearing (Style II).

On Style IV, Style II/IV, Style III/IV, and Style IV/IV transmissions, it is necessary to determine the overhung load at the shaft connected to the 2-stage or 3-stage gearing. Overhung load is a function of the connecting media and the following factors should be in the formula for calculating the overhung load.

Chain – 1.0
 Gear – 1.25
 V-Belt – 1.5
 Flat Belt – 2.5

$$L = \frac{2 T F}{D}$$

L = Overhung Load (Lb.)
 T = Torque (Lb. In.)
 F = Factor (Table Above)
 D = Pitch Diameter

SERVICE INFORMATION

A list of replacement parts and instructions for servicing the variable speed transmission are available in the Installation, Operating and Maintenance Instructions Bulletin 207-IOM and Bulletin 207-84 IOM.

RATING TABLE

-66,-71,-79 CONFIGURATION

UNIT SIZE	MODEL NUMBER	SPEED RANGE	CONTROL SCREW TURNS	INPUT R.P.M.	OUTPUT TORQUE* & POWER CAPACITY						CHAIN NUMBER
					AT MAXIMUM SPEED			AT MINIMUM SPEED			
					TORQUE*	R.P.M.	H.P.	TORQUE*	R.P.M.	H.P.	
0	02	2:1	5.0	720	55	1018	.89	85	509	.69	00232
	03	3:1	6.5	720	45	1245	.89	85	415	.56	00431
	04	4:1	8.0	720	40	1440	.91	80	360	.46	00431
	05	5:1	8.2	720	35	1610	.89	80	322	.41	00530
1/2	1/2-2	2:1	5.5	720	90	1018	1.45	140	509	1.13	05238
	1/2-3	3:1	7.5	720	80	1245	1.58	140	415	.92	05436
	1/2-4	4:1	9.5	720	65	1440	1.49	140	360	.80	05436
1	12-72,79	2:1	8.0	900	140	1273	2.8	200	636	2	21227
	13-72,79	3:1	10.5	900	115	1559	2.8	200	520	1.6	21625
	14-72,79	4:1	12.5	900	100	1800	2.8	200	450	1.4	21625
	15-72,79	5:1	13.0	720	75	1610	1.9	165	322	.8	21625
	16-72,79	6:1	14.3	720	65	1764	1.8	165	294	.76	21625
2	22	2:1	6.0	900	215	1273	4.3	315	636	3.2	32231
	23	3:1	8.0	900	190	1559	4.7	330	520	2.7	22434
	24	4:1	9.8	900	165	1800	4.7	330	450	2.4	22434
	25	5:1	10.3	720	150	1610	3.8	330	322	1.7	22633
	26	6:1	11.0	720	115	1764	3.2	330	294	1.5	22633
3	32	2:1	7.1	900	340	1273	6.9	495	636	5.0	33237
	33	3:1	10.1	900	285	1559	7.1	495	520	4.1	33436
	34	4:1	12.4	900	250	1800	7.1	495	450	3.6	33436
	35	5:1	13.0	720	195	1610	5.0	440	322	2.2	33635
	36	6:1	14.2	720	180	1764	5.0	440	294	2.1	33635
4	42	2:1	8.5	720	575	1018	9.3	825	509	6.7	44237
	43	3:1	11.4	720	470	1247	9.3	855	416	5.6	44435
	44	4:1	13.9	720	405	1440	9.3	810	360	4.6	44435
	45	5:1	14.5	600	330	1342	7.0	825	268	3.5	44634
	46	6:1	15.8	600	300	1470	7.0	770	245	3.0	44634
5	52	2:1	9.2	720	955	1018	15.4	1400	509	11.3	55247
	53	3:1	13.4	720	780	1247	15.4	1510	416	10.0	55445
	54	4:1	15.5	720	675	1440	15.4	1510	360	8.6	55445
	55	5:1	16.5	600	565	1342	12.0	1550	268	6.6	55644
	56	6:1	18.0	600	515	1470	12.0	1550	245	6.0	55644

*Torque shown in pound-inches.

RATING TABLE

-84 CONFIGURATION

UNIT SIZE	MODEL NUMBER	SPEED RANGE	CONTROL SCREW TURNS	INPUT R.P.M.	OUTPUT TORQUE* & POWER CAPACITY						CHAIN NUMBER
					AT MAXIMUM SPEED			AT MINIMUM SPEED			
					TORQUE*	R.P.M.	H.P.	TORQUE*	R.P.M.	H.P.	
0	02-84	2:1	4.4	720	55	1018	.89	85	509	.69	A032
	03-84	3:1	6.3	720	45	1245	.89	85	415	.56	A031
	04-84	4:1	7.6	720	40	1440	.91	80	360	.46	A031
	05-84	5:1	8.0	720	35	1610	.89	80	322	.41	A030
1/2	1/2-2-84	2:1	5.3	720	90	1018	1.45	140	509	1.13	A038
	1/2-3-84	3:1	7.1	720	80	1245	1.58	140	415	.92	A036
	1/2-4-84	4:1	8.8	720	65	1440	1.49	140	360	.80	A036
1	12-84	2:1	7.1	900	140	1273	2.8	200	636	2.	A227
	13-84	3:1	8.9	900	115	1559	2.8	200	520	1.6	A225
	14-84	4:1	11.0	900	100	1800	2.8	200	450	1.4	A225
	15-84	5:1	12.6	720	75	1610	1.9	165	322	.8	A225
	16-84	6:1	13.8	720	65	1764	1.8	165	294	.76	A225
2	22-84	2:1	5.5	900	215	1273	4.3	315	636	3.2	A330
	23-84	3:1	7.3	900	190	1559	4.7	330	520	2.7	A233
	24-84	4:1	9.1	900	165	1800	4.7	330	450	2.4	A233
	25-84	5:1	9.4	720	150	1610	3.8	330	322	1.7	A232
	26-84	6:1	10.4	720	115	1764	3.2	330	294	1.5	A232
3	32-84	2:1	7.1	900	340	1273	6.9	495	636	5.0	A337
	33-84	3:1	9.4	900	285	1559	7.1	495	520	4.1	A335
	34-84	4:1	11.7	900	250	1800	7.1	495	450	3.6	A335
	35-84	5:1	12.1	720	195	1610	5.0	440	322	2.2	A334
	36-84	6:1	13.4	720	180	1764	5.0	440	294	2.1	A334
4	42-84	2:1	8.5	720	575	1018	9.3	825	509	6.7	A437
	43-84	3:1	11.4	720	470	1247	9.3	855	416	5.6	A435
	44-84	4:1	13.9	720	405	1440	9.3	810	360	4.6	A435
	45-84	5:1	14.5	600	330	1342	7.0	825	268	3.5	A434
	46-84	6:1	15.8	600	300	1470	7.0	770	245	3.0	A434

*Torque shown in pound-inches.

ASSEMBLY ARRANGEMENTS

All optional items are furnished at additional cost. (see price list)

Note: See Style Configurations to determine shaft direction of rotation for specific assembly

STYLE I — Horizontal

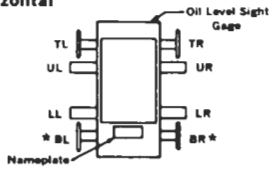

Standard units are supplied with the control screw at either Position "TL" or "TR" — that is, at the oil level sight gage end of the transmission. Specify desired position. As an option, the transmission can be supplied with the control screw at Positions "BL" or "BR". Not available on size 0.

Specify desired shaft positions by designating LL, L.R, UL or UR as indicated. Input and output shafts cannot be in line. Input and output shafts can be on the same side or opposite sides of the transmission. Input and/or output shafts can be double extended.

STYLE II/II — Horizontal

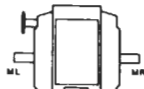

ASSEMBLY 1

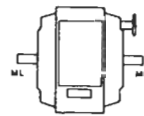

ASSEMBLY 2

Standard units are supplied with the oil sight gage at the control screw end of the transmission. As an option, the transmission can be supplied with the oil gage at the opposite end.

Designate input and output shaft.

STYLE III/II — Horizontal

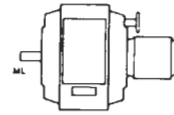

ASSEMBLY 1

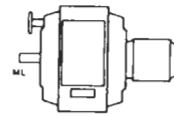

ASSEMBLY 2

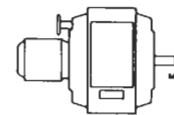

ASSEMBLY 3

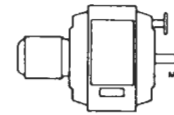

ASSEMBLY 4

Standard units are supplied with the oil sight gage at the control screw end of the transmission. As an option, the transmission can be supplied with the oil gage at the opposite end.

STYLE II — Horizontal

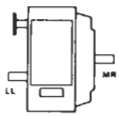

ASSEMBLY 1

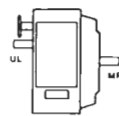

ASSEMBLY 2

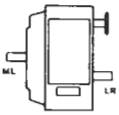

ASSEMBLY 3

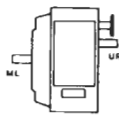

ASSEMBLY 4

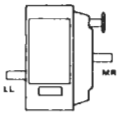

ASSEMBLY 5

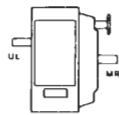

ASSEMBLY 6

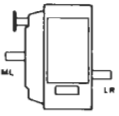

ASSEMBLY 7

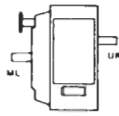

ASSEMBLY 8

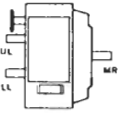

ASSEMBLY 9

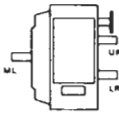

ASSEMBLY 10

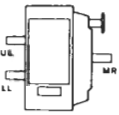

ASSEMBLY 11

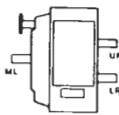

ASSEMBLY 12

Standard units are supplied with the oil sight gage at the control screw end of the transmission. As an option, the transmission can be supplied with the oil gage at the opposite end.

Designate position of adjustable speed shaft and constant speed shaft. Assemblies 9 through 12 can be supplied with two (2) adjustable speed shafts and one (1) constant speed shaft, or one (1) adjustable speed shaft and two (2) constant speed shafts. Both adjustable or constant speed shafts cannot be on the same side of the transmission.

STYLE III — Horizontal

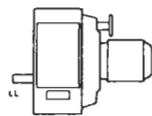

ASSEMBLY 1

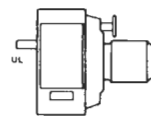

ASSEMBLY 2

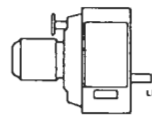

ASSEMBLY 3

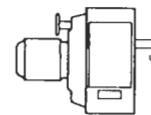

ASSEMBLY 4

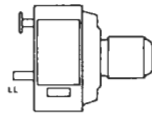

ASSEMBLY 5

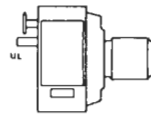

ASSEMBLY 6

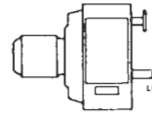

ASSEMBLY 7

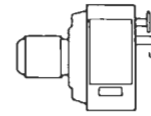

ASSEMBLY 8

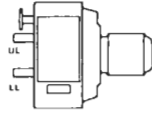

ASSEMBLY 9

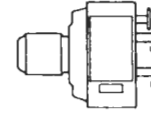

ASSEMBLY 10

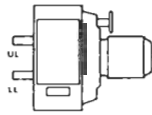

ASSEMBLY 11

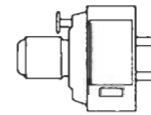

ASSEMBLY 12

Standard units are supplied with the oil sight gage at the control screw end of the transmission. As an option, the transmission can be supplied with the oil gage at the opposite end.

On assemblies 9 through 12 designate position of adjustable speed shaft and constant speed shaft.

STYLE I — Vertical

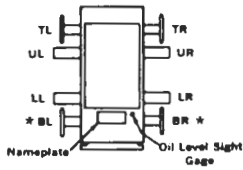

Standard units are supplied with the control screw at Positions "TL" or "TR." Specify desired position. As an option, the transmission can be supplied with the control screw at Positions "BL" or "BR." (Not available on size 0.)
Specify desired shaft positions by designating LL, LR, UL or UR as indicated. Input and output shafts cannot be in line. Input and output shafts can be on the same side or opposite sides of the transmission. Input and/or output shafts can be double extended.

STYLE II/II — Vertical

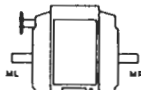

ASSEMBLY 1

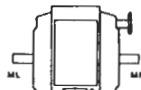

ASSEMBLY 2

Standard units are supplied with the control screw at the top. As an option, the transmission can be supplied with the control screw at the bottom.
Designate input and output shaft.

STYLE III/II — Vertical

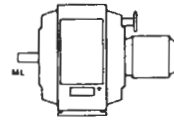

ASSEMBLY 1

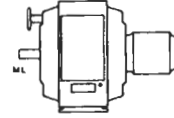

ASSEMBLY 2

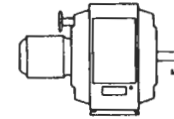

ASSEMBLY 3

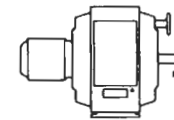

ASSEMBLY 4

Standard units are supplied with the control screw at the top. As an option, the transmission can be supplied with the control screw at the bottom.

STYLE II — Vertical

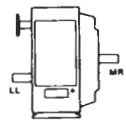

ASSEMBLY 1

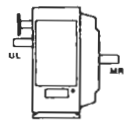

ASSEMBLY 2

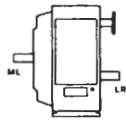

ASSEMBLY 3

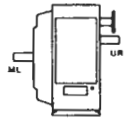

ASSEMBLY 4

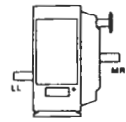

ASSEMBLY 5

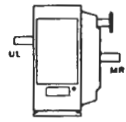

ASSEMBLY 6

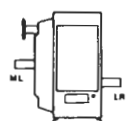

ASSEMBLY 7

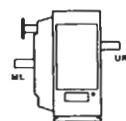

ASSEMBLY 8

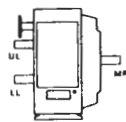

ASSEMBLY 9

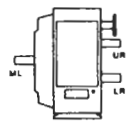

ASSEMBLY 10

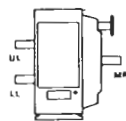

ASSEMBLY 11

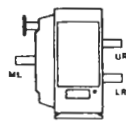

ASSEMBLY 12

Standard units are supplied with the control screw at the top. As an option, the transmission can be supplied with the control screw at the bottom.

Designate position of adjustable speed shaft and constant speed shaft. Assemblies 9 through 12 can be supplied with two (2) adjustable speed shafts and one (1) constant speed shaft, or one (1) adjustable speed shaft and two (2) constant speed shafts. Both adjustable or constant speed shafts cannot be on the same side of the transmission.

STYLE III — Vertical

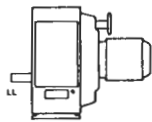

ASSEMBLY 1

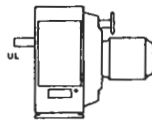

ASSEMBLY 2

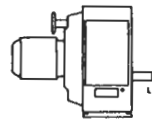

ASSEMBLY 3

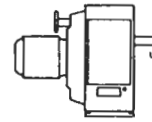

ASSEMBLY 4

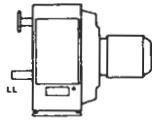

ASSEMBLY 5

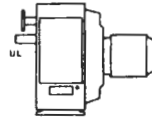

ASSEMBLY 6

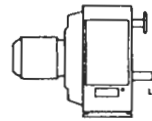

ASSEMBLY 7

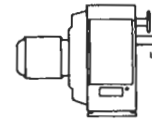

ASSEMBLY 8

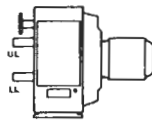

ASSEMBLY 9

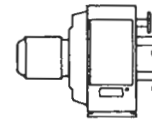

ASSEMBLY 10

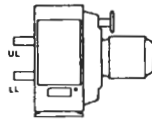

ASSEMBLY 11

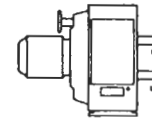

ASSEMBLY 12

Standard units are supplied with the control screw at the top. As an option, the transmission can be supplied with the control screw at the bottom. On assemblies 9 through 12 designate position of adjustable speed shaft and constant speed shaft.

STYLE IV — Horizontal

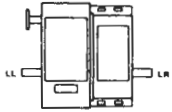

ASSEMBLY 1

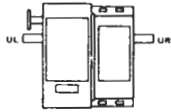

ASSEMBLY 2

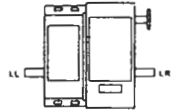

ASSEMBLY 3

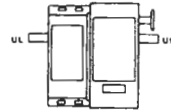

ASSEMBLY 4

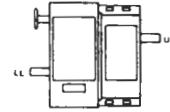

ASSEMBLY 5

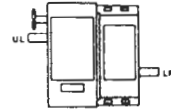

ASSEMBLY 6

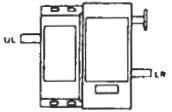

ASSEMBLY 7

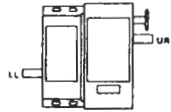

ASSEMBLY 8

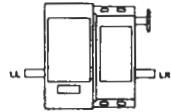

ASSEMBLY 9

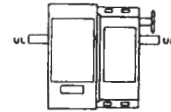

ASSEMBLY 10

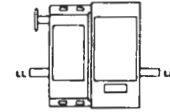

ASSEMBLY 11

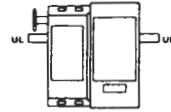

ASSEMBLY 12

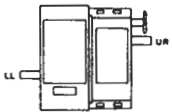

ASSEMBLY 13

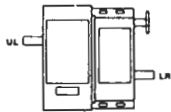

ASSEMBLY 14

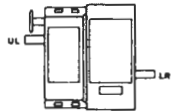

ASSEMBLY 15

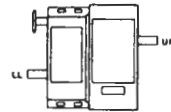

ASSEMBLY 16

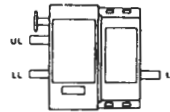

ASSEMBLY 17

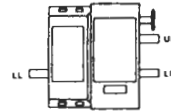

ASSEMBLY 18

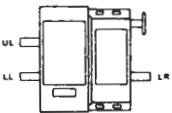

ASSEMBLY 19

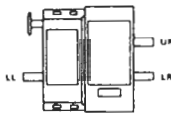

ASSEMBLY 20

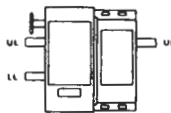

ASSEMBLY 21

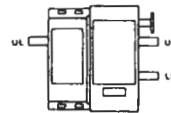

ASSEMBLY 22

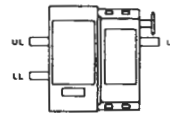

ASSEMBLY 23

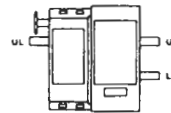

ASSEMBLY 24

Standard units are supplied with the oil sight gage at the control screw end of the transmission. As an option, the transmission can be supplied with the oil gage at the opposite end.

Designate position of adjustable speed shaft and constant speed shaft. Assemblies 17 through 24 can be supplied with two (2) adjustable speed shafts and one (1)

constant speed shaft, or one (1) adjustable speed shaft and two (2) constant speed shafts. Both adjustable or constant speed shafts cannot be on the same side of the transmission. (Not available in size 0.)

STYLE IV/II — Horizontal

Not available in size 0

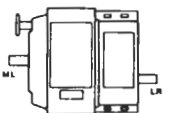

ASSEMBLY 1

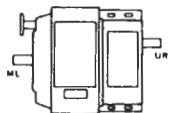

ASSEMBLY 2

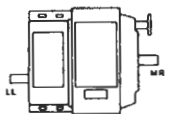

ASSEMBLY 3

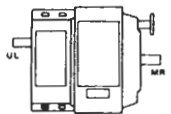

ASSEMBLY 4

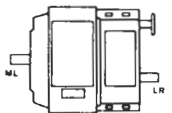

ASSEMBLY 5

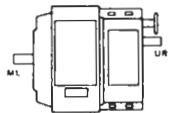

ASSEMBLY 6

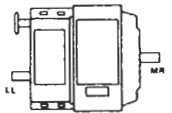

ASSEMBLY 7

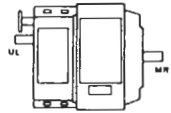

ASSEMBLY 8

Standard units are supplied with the oil sight gage at the control screw end of the transmission. As an option, the transmission can be supplied with the oil gage at the opposite end.

Designate input and output shaft.

STYLE IV/III — Horizontal

Not available in size 0

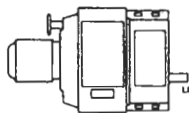

ASSEMBLY 1

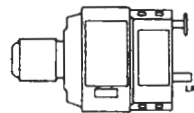

ASSEMBLY 2

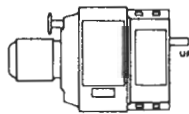

ASSEMBLY 3

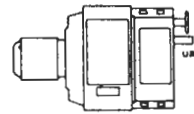

ASSEMBLY 4

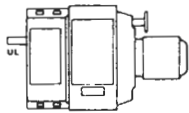

ASSEMBLY 5

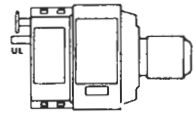

ASSEMBLY 6

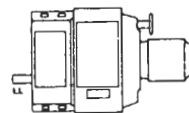

ASSEMBLY 7

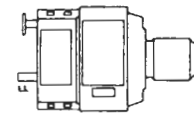

ASSEMBLY 8

Standard units are supplied with the oil sight gage at the control screw end of the transmission. As an option, the transmission can be supplied with the oil gage at the opposite end.

STYLE IV/IV — Horizontal

Not available in size 0

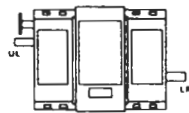

ASSEMBLY 1

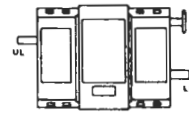

ASSEMBLY 2

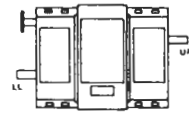

ASSEMBLY 3

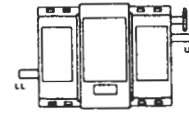

ASSEMBLY 4

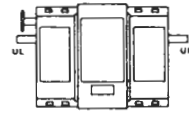

ASSEMBLY 5

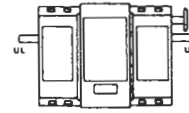

ASSEMBLY 6

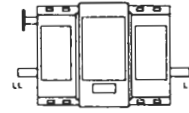

ASSEMBLY 7

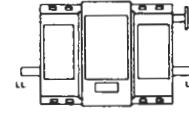

ASSEMBLY 8

Standard units are supplied with the oil sight gage at the control screw end of the transmission. As an option, the transmission can be supplied with the oil gage at the opposite end.

Designate input and output shaft.

STYLE IV — Vertical

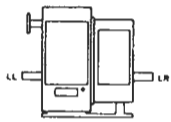

ASSEMBLY 1

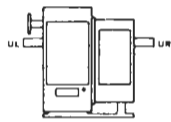

ASSEMBLY 2

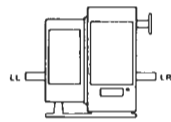

ASSEMBLY 3

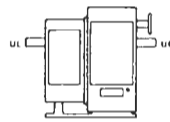

ASSEMBLY 4

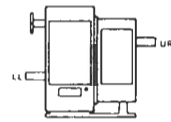

ASSEMBLY 5

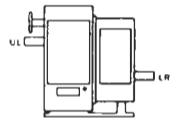

ASSEMBLY 6

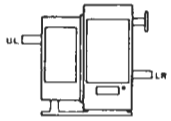

ASSEMBLY 7

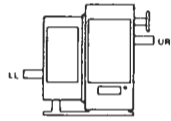

ASSEMBLY 8

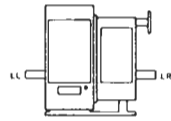

ASSEMBLY 9

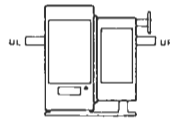

ASSEMBLY 10

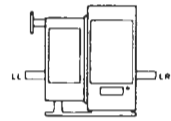

ASSEMBLY 11

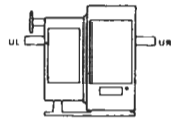

ASSEMBLY 12

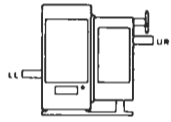

ASSEMBLY 13

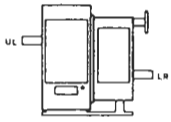

ASSEMBLY 14

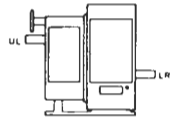

ASSEMBLY 15

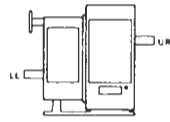

ASSEMBLY 16

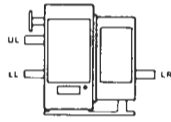

ASSEMBLY 17

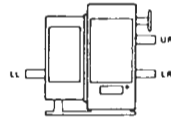

ASSEMBLY 18

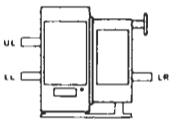

ASSEMBLY 19

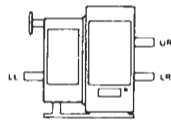

ASSEMBLY 20

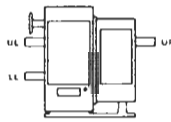

ASSEMBLY 21

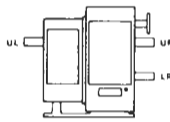

ASSEMBLY 22

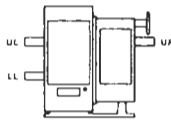

ASSEMBLY 23

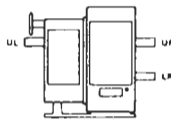

ASSEMBLY 24

Standard units are supplied with the control screw at the top. As an option, the transmission can be supplied with the control screw at the bottom.

Designate position of adjustable speed shaft and constant speed shaft. Assemblies 17 through 24 can be supplied with two (2) adjustable speed shafts and one (1)

constant speed shaft, or one (1) adjustable speed shaft and two (2) constant speed shafts. Both adjustable or constant speed shafts cannot be on the same side of the transmission. (Not available in size 0.)

STYLE IV/II — Vertical

Not available in size 0

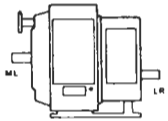

ASSEMBLY 1

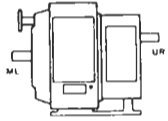

ASSEMBLY 2

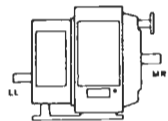

ASSEMBLY 3

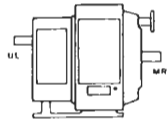

ASSEMBLY 4

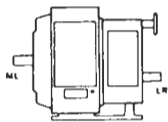

ASSEMBLY 5

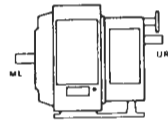

ASSEMBLY 6

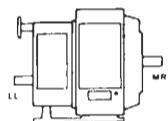

ASSEMBLY 7

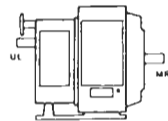

ASSEMBLY 8

Standard units are supplied with the control screw at the top. As an option, the transmission can be supplied with the control screw at the bottom.

Designate input and output shaft.

STYLE IV/III — Vertical

Not available in size 0

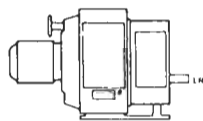

ASSEMBLY 1

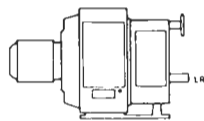

ASSEMBLY 2

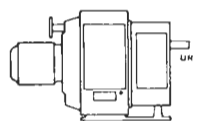

ASSEMBLY 3

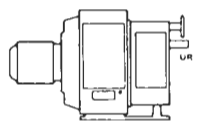

ASSEMBLY 4

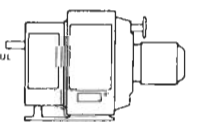

ASSEMBLY 5

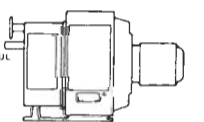

ASSEMBLY 6

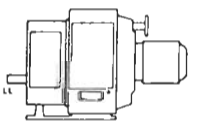

ASSEMBLY 7

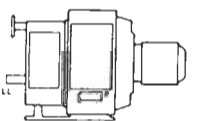

ASSEMBLY 8

Standard units are supplied with the control screw at the top. As an option, the transmission can be supplied with the control screw at the bottom.

STYLE IV/IV — Vertical

Not available in size 0

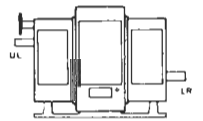

ASSEMBLY 1

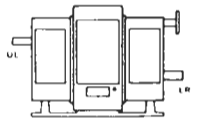

ASSEMBLY 2

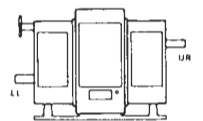

ASSEMBLY 3

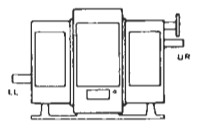

ASSEMBLY 4

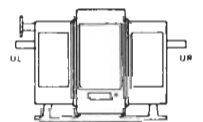

ASSEMBLY 5

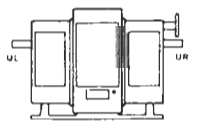

ASSEMBLY 6

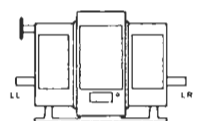

ASSEMBLY 7

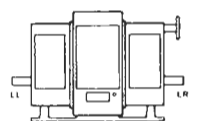

ASSEMBLY 8

Standard units are supplied with the control screw at the top. As an option, the transmission can be supplied with the control screw at the bottom.

Designate input and output shaft.

Consult the factory for overhung load ratings for these transmissions.

De-rating speeds lower than shown in the rating table will affect the HP and output RPM in direct proportion to the difference in input speed.

Slow Speed Applications – On slow speed applications, operating speeds should be specified for consideration of special lubrication.

OPTIONS

The Specon VARI-CHAIN Transmission is normally supplied with the standard manual control. Other types of control, such as remote, vernier, remote vernier, lever, electrical, pneumatic and hydraulic are available.

Manual Control

Specon VARI-CHAIN transmissions are normally supplied with a hand knob on the adjusting screw for normal manual adjustment. The adjusting knob includes an indicator mechanism which accurately indicates turns and parts of turns of the adjusting screw. Output speed setting is a definite function of adjusting screw turns and thus the handwheel indicator accurately reflects output speed setting or ratio.

Mechanical Remote Control

Mechanical Remote Control is an indicator and hand-wheel assembly which can be remotely mounted from the transmission. It can be connected by roller chain or flexible shafting to the adjusting screw of the transmission. Thus normal manual control can be achieved from a remote position.



Vernier Control

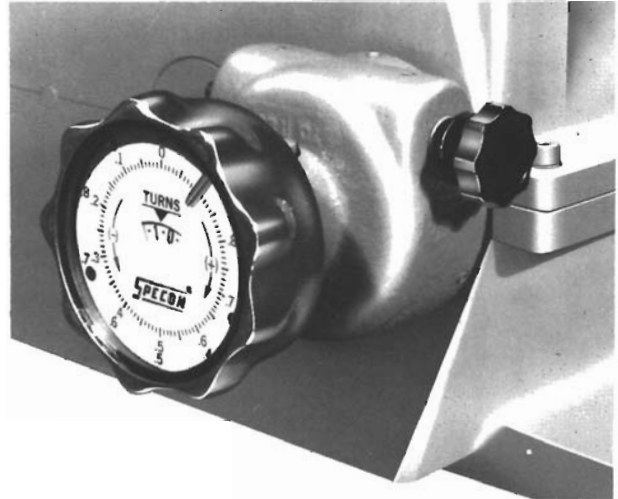

Vernier Control consists of a small worm and worm gear package connected to the adjusting screw which permits finer adjusting of output speed per turn of the adjusting hand knob.

The worm gear ratio can be provided either in a $7\frac{1}{2}:1$ or a $30:1$ ratio. The vernier control package contains both a rough and fine adjusting handwheel. For example, on a Model 14 VARI-CHAIN Transmission, 13.2 turns of the control screw are required to adjust through full range with the standard manual control. The same number of turns of the rough adjusting handwheel on the vernier would give full range adjustment. The number of turns required on the fine adjusting handwheel of the vernier control would be $7\frac{1}{2}$ or 30 times 13.2 depending on which ratio was specified. This control can be provided as an integral part of the Specon transmission, in which case it is located at the adjusting screw position. The same accurate indicating handwheel as is used on the remote control can be used on the course adjusting shaft of the vernier control. Thus a fine degree of repeatability can be achieved.

Remote Vernier Control

The Remote Vernier Control accessory utilizes the same construction and offers the same features as the integral vernier control. It can, however, be remotely mounted from the transmission and connected to the adjusting screw of the transmission by roller chain or flexible shafting. The remote vernier control also has a coarse adjusting handwheel and a fine adjusting handwheel.

Preloading

Specon VARI-CHAIN transmissions can, as an option, be provided with preloaded control levers. This preloading feature incorporates a tension or compression spring between the control levers of the transmission which preloads the control mechanism and reduces the play resulting from manufacturing and assembly tolerances.

The overall effect of this feature is to improve the operating accuracy of the transmission under constant load conditions.

When specifying preloading, it is necessary to also define the position of the control screw relative to the constant speed or variable speed shaft and whether the load is a normal driving or overhauling load.

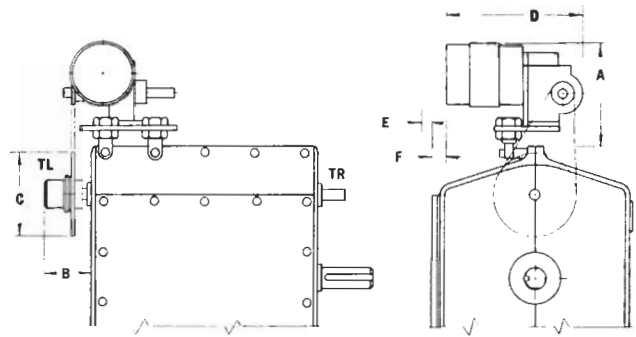

Unit Size	A	B	C	D	E	F
0	5 $\frac{7}{16}$	1 $\frac{7}{8}$	3 $\frac{15}{16}$	7 $\frac{3}{8}$	1 $\frac{1}{2}$	
$\frac{1}{2}$	5 $\frac{3}{8}$	1 $\frac{7}{8}$	3 $\frac{15}{16}$	7 $\frac{3}{8}$	$\frac{7}{16}$	
1	5 $\frac{3}{8}$	2 $\frac{1}{2}$	3 $\frac{15}{16}$	7 $\frac{3}{8}$	$\frac{7}{16}$	
2	5 $\frac{3}{8}$	2 $\frac{1}{2}$	4 $\frac{33}{64}$	7 $\frac{3}{8}$		$\frac{3}{4}$
3	5 $\frac{1}{4}$	2 $\frac{1}{2}$	4 $\frac{33}{64}$	7 $\frac{3}{8}$		1 $\frac{3}{8}$
4	6 $\frac{3}{4}$	2 $\frac{5}{8}$	4 $\frac{33}{64}$	13 $\frac{13}{16}$	2 $\frac{1}{8}$	
5	6 $\frac{3}{4}$	2 $\frac{5}{8}$	4 $\frac{33}{64}$	13 $\frac{13}{16}$	$\frac{5}{8}$	

Electric Remote Control

Electric Remote Control can also be made available on the Specon VARI-CHAIN Transmission. The remote control consists of a reversible gear head motor with a very slow output speed.

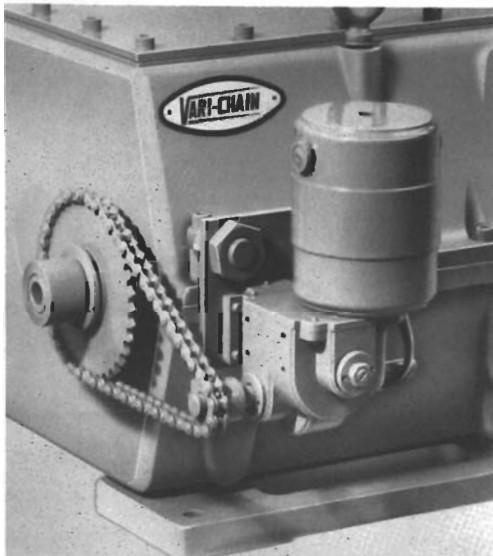

The output shaft of the gear head motor is connected to the adjusting screw with roller chain. A mechanical slip clutch is included to protect the control and motor when the control levers in the VARI-CHAIN unit have reached the end of travel. Electric service can be 115V or 230V A/C or D/C single phase or 230V to 575V multiphase A/C.

Pneumatic Control

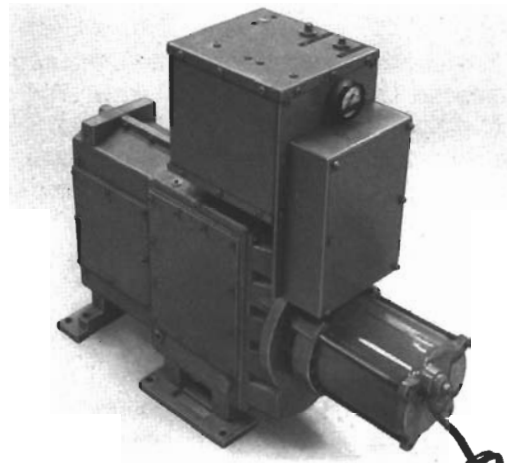

Recommended for operation in an explosive atmosphere or on automatic control loops or where rapid response is desirable. Three types of pneumatic controls are available:

1. Reversible air motor with pushbutton station for remote operator control. By appropriate use of pneumatic relays, remote control from several hundred feet can be achieved.
2. New design consisting of an air motor and appropriate interconnected pressure regulators, relays, & valves requiring standard signal pressures such as 3-15 PSI to control through full speed range of transmission.
3. Pneumatic cylinder used with right angle lever control for continuous speed range changes. Signal pressure 3-15 PSI.

Systems 2 & 3 are suitable for automatic control systems requiring only 3-15 PSI signal pressure from a process controlling element.

ORDERING INFORMATION

Tach-Generator



The Specon tachometer-generator and readout system is designed for industrial applications. The panel mount indicator may be calibrated in RPM, FPM, or other units. Typical ranges available are 0-100, 0-250, 0-500, 0-1000 and 0-2000 RPM with a calibrated system accuracy within 1% of full scale reading. The generator is enclosed in a weatherproof housing with a 1/2" diameter output shaft extension, bearing mounted and designed for industrial applications.

The generator may be furnished with a bracket for remote mounting or direct flange mounted units are also available when ordered as part of a Specon VARI-CHAIN variable speed transmission.

When ordering specify:

Model # (Size & ratio range – See rating tables page 16, 17.)

Style I, II, II/II, III, III/II IV, IV/II, IV/III, or IV/IV. (See Pages 13 and 14.)

Horizontal or Vertical Mounting

Assembly Number (See Pages 18 and 21.)

Control Screw Location (See Pages 18 through 21.)

Shaft Locations (See Pages 18 through 21.)

Ratio (For Style II, III & IV Only – See Pages 3 and 4.)

For example:

No. 1 – Specon Model 24 VARI-CHAIN Transmission

Style I, Horizontal

Shaft extensions at LL & UR

Control screw at TL

No. 2 – Specon Model 24 VARI-CHAIN Transmission

Style II, Vertical

Assembly 6

Output gear ratio – 2.030:1

Output speed – 888-222 RPM

No. 3 – Specon Model 24 VARI-CHAIN Transmission

Style III/II, Horizontal Assembly No. 3

Output gear ratio – 3:1

Output speed 600-150 RPM

Integral 5 HP – 230/460 – 60 cycle

3 phase – Open drip-proof a-c motor.

FAIRCHILD

INDUSTRIAL PRODUCTS COMPANY

3920 WEST POINT BLVD. • WINSTON-SALEM, NC 27103-6708 • USA
TELEPHONE 336/659-3400 1-800-334-8422 FAX 336/659-9323

FOR TOTAL CONTROL WHEN THE POWER'S ON.



MECHANICAL
& ELECTRO –
MECHANICAL
POWER
TRANSMISSION
EQUIPMENT



FM NO. 25571